

MOULDING LINE 275

USER AND SERVICE MANUAL



PREFAZIONE

SELM S.r.l. would like to thank you for purchasing our "MOULDING LINE 275".

This manual is to be considered an integral part of the machine and its purpose is to allow use of the machine throughout its life, from delivery until demolition. Therefore, we suggest that you read it carefully. Everyone working with the machine must read this manual. It is also necessary to keep the manual in a place accessible to operators at all times.

In the event of loss or damage of this manual, please ask **SELM** S.r.l. to send you a replacement copy.

The technical information contained in this manual belongs to **SELM** S.r.l. and must be considered proprietary.

The total or partial reproduction of the graphic design, text and illustrations is forbidden

With a view to constant technical improvement, the company reserves the right to make any necessary amendments to the content of the manual, to the machine or to parts thereof. Consequently, some of the illustrations may differ slightly from your machine.

This document is an integral part of the "MOULDING LINE 275", as described in section 1.7.4 of annex I of directive 2006/42/EC.

The Italian edition of this manual contains the original instructions. The foreign language editions are to be considered as translations of the original instructions.

© Copyright **SELM** S.r.l.
Edition August 2019

EC DECLARATION OF CONFORMITY

The manufacturing company **SELM** S.r.l., with main office in S. Vittoria D'Alba (CN) Italy – Via Statale, 151, in its capacity as manufacturer, declares, under its own responsibility, that the machine named:

"MOULDING LINE 275"

Serial number

is compliant with all the provisions contained in the following directives: 2006/42/EC (machine directive), 2014/30/UE (electromagnetic compatibility) 2014/35/UE (low voltage directive) and EC regulation 1935/2004 (contact with foodstuffs).

The norms adhered to that are used as a reference for the design, realization and testing of the machine are listed in the technical files archived at Selmi Srl.

The manufacturer also wishes to inform you that the technical file may, in the cases envisaged by the directive, be put together by the manufacturing company.

Year of construction

Date



Il responsabile

1. General information	4	3. Moving and transportation section	22
1.1. Structure of the manual	4	3.1. General norms	22
1.2. Messages Used	4	3.2. Packaging	22
1.3. Aim and contents	4	3.3. Transportation	23
1.4. Preservation of the manual	4	3.4. Removal of the packaging	23
1.5. Components	5	4. Installation section	23
1.6. Components	5	4.1. Positioning	23
1.7. Details of the manufacturer	13	4.2. Electrical connections	23
1.8. Identification plate of the machine	13	5. Operation section	21
1.9. Identification plate of the CE marking	13	6. Technical diagrams section	28
1.10. Inteded use	13		
1.11. Operating environment	13		
1.12. Noise level	13		
1.13. Technical characteristics	11		
1.14. Dimensions	11		
1.15. Storage	15		
1.16. Disposal	15		
1.17. Warranty	15		
1.18. person qualified to operate	16		
2. Safety section	17		
2.1. Safety information	17		
2.2. Safety limitations	17		
2.3. Safety symbols and plaques	18		
2.4. Safety and protection devices	18		
2.5. Client's safety measures	19		
2.6. Personal protection equipment	19		
2.7. Residual risks	20		
2.8. Applied Directives	21		
2.9. Harmonized technical norms	21		

1. General information

1.1. Structure of the manual

To simplify the reading and understanding of the information contained in this manual and to make searches quicker, it has been divided into sections, each dedicated to a specific subject.

1.2. Messages used

Attention

This type of message is used to draw the reader's attention to more delicate or particular procedures which, if not carried out correctly, may pose a risk to the safety of the operator and cause damage to parts of the machine.

Warning

This type of message is used to draw the reader's attention to procedures which, if not carried out correctly or at pre-set intervals, may cause damage to the machine or its parts, as well as to the product being processed.

Environment

Messages relating to the environment draw the operator's attention to the rules to be followed to prevent the risk of environmental damages deriving, directly or indirectly, from use of the machine.

Note

These messages highlight instructions, advice and notes that can be particularly helpful during the various uses of the machine.

1.3. Aim and contents

This manual has been drawn up in consideration of the requirements of directive 2006/42/EC and paying particular attention to describing all the procedures necessary to obtain the best working conditions for the machine and its operators, without neglecting product quality:

The aim of this manual is, therefore, to provide the user with all the information necessary for the correct use and maintenance of the machine. Consequently it is absolutely necessary:

- to meticulously follow the instructions given in the manual during every phase of the machine's life, from transportation to demolition;
- for every machine operator to thoroughly read the contents of this manual;
- for the company's safety officer to make sure that all machine operators have clearly understood how the machine works

Attention

In case of doubts on the correct interpretation of the instructions please contact the manufacturer to obtain the necessary clarifications. All those carrying out any kind of operation on the machine must have thoroughly read and understood the contents of this instruction manual.

Warning

If this manual is damaged or lost, please ask the manufacturer or the authorised distributor in the country where the machine is being used for another copy.

1.4. Preservation of the manual

The instruction manual is an integral part of the machine and must be used to train and inform professional figures operating on the machine. Consequently, it is necessary to follow certain simple instructions regarding its preservation, as follows:

- store the manual in areas protected from humidity and heat, so as not to jeopardise the quality or legibility of any part of the publication;
- keep the manual in an easily accessible place known to the machine operators;
- avoid handling the manual with dirty or greasy hands;
- if you think it is necessary to highlight important steps of the manual, use non-permanent systems, to preserve its legibility;
- do not remove, rip or rewrite any parts of the manual for any reason.

1.5. Components

- 1 Moulds hopper
- 2 Tempering machine (not included)
- 3 Filling area: the mould is filled by the injection plate and vibrated.
- 4 Overturn area: the mould is overturned, cleaned with scrapers, vibrated, and overturned again to the original position.
- 5 Final scraper: Mould is cleaned by a final scraper
- 6 Tank protection door.
- 7 Front protection panel
- 8 Swivelling Wheels
- 9 Electrical panel

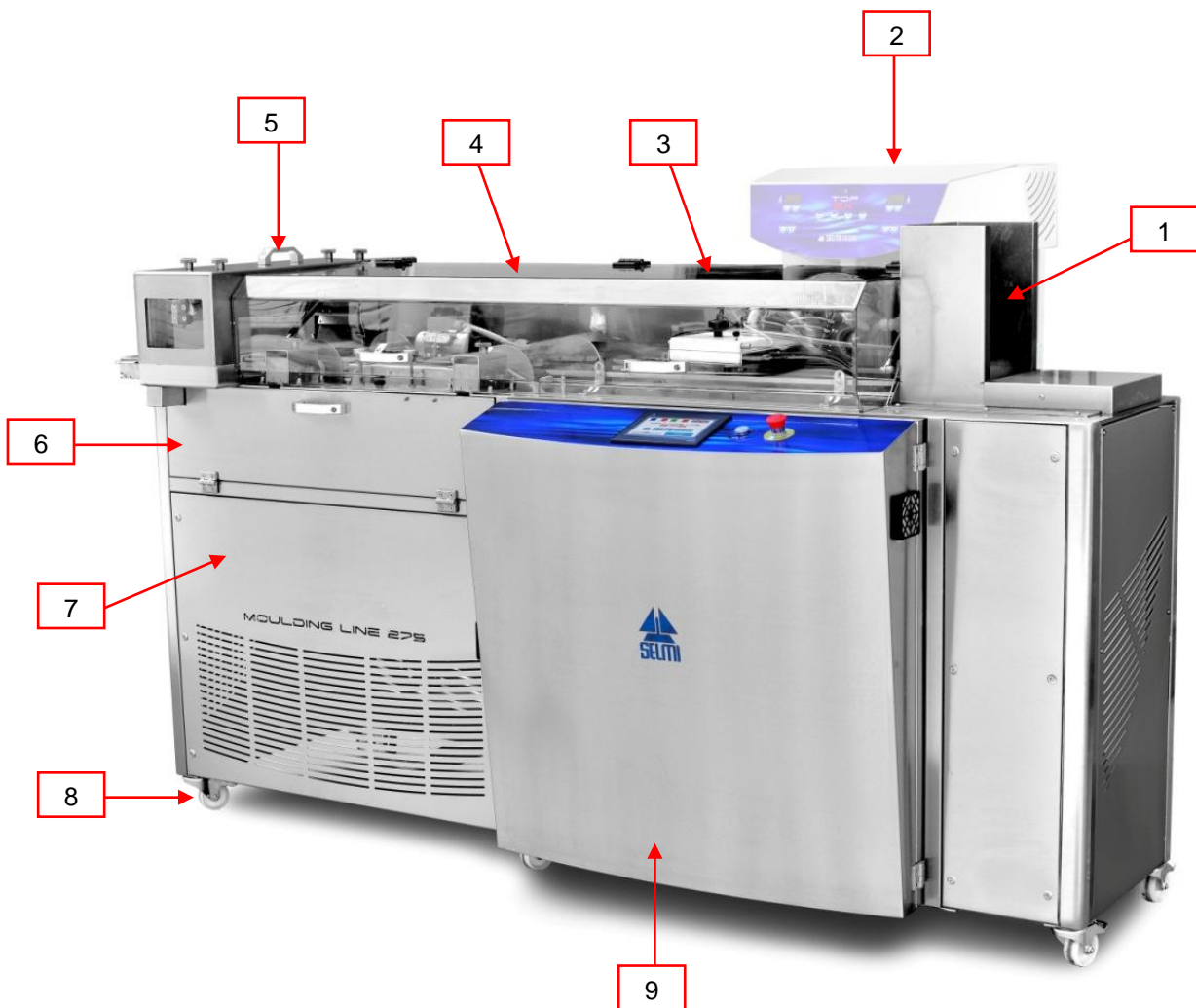

FILLING AREA

1. Mould loading hopper
2. Micro security for the plexiglass cover
3. Injection head
4. Piston that is pushing the moulds toward the moulding area
5. Command Display
6. Start / reset button
7. Emergency button

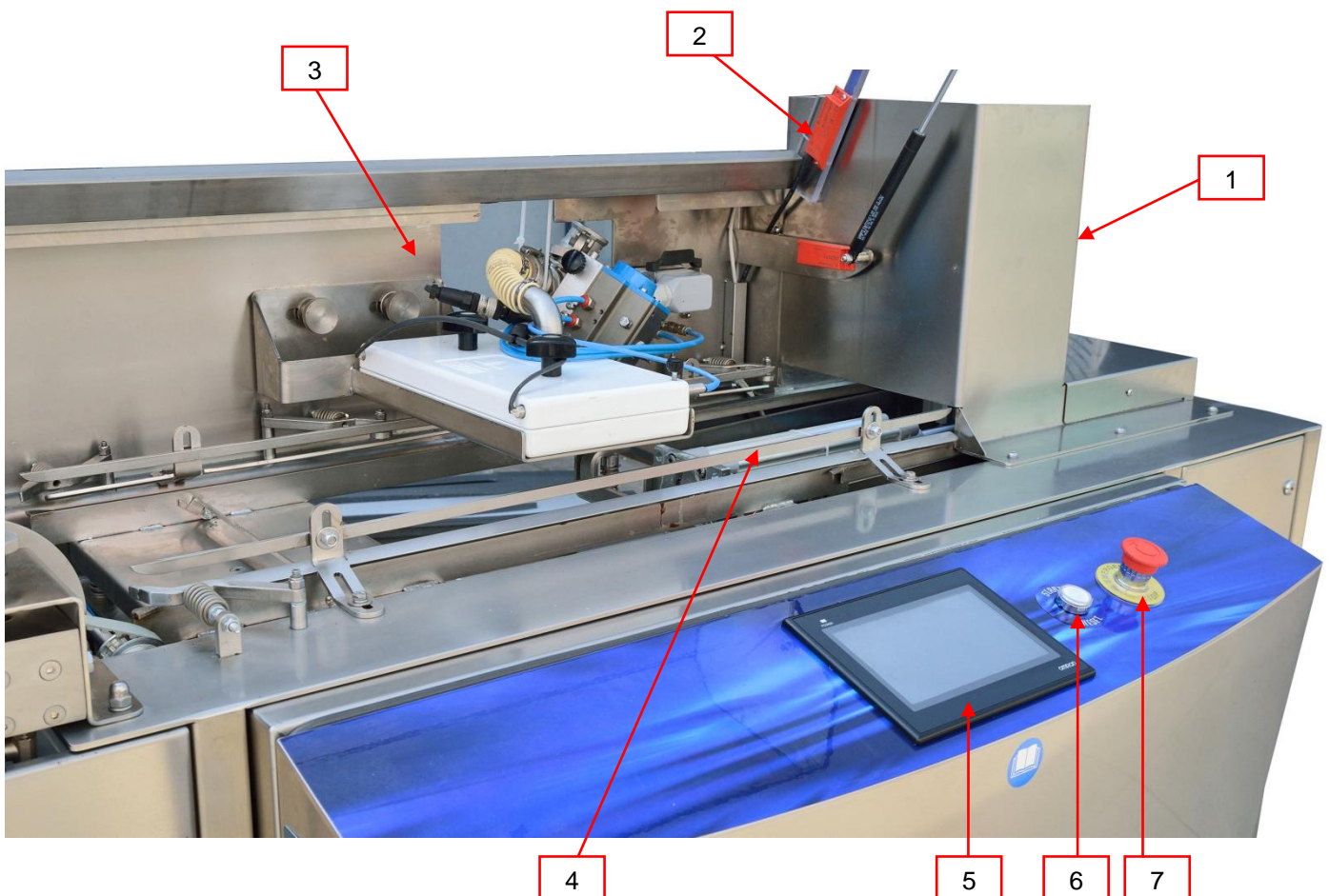

FILLING AREA DETAIL

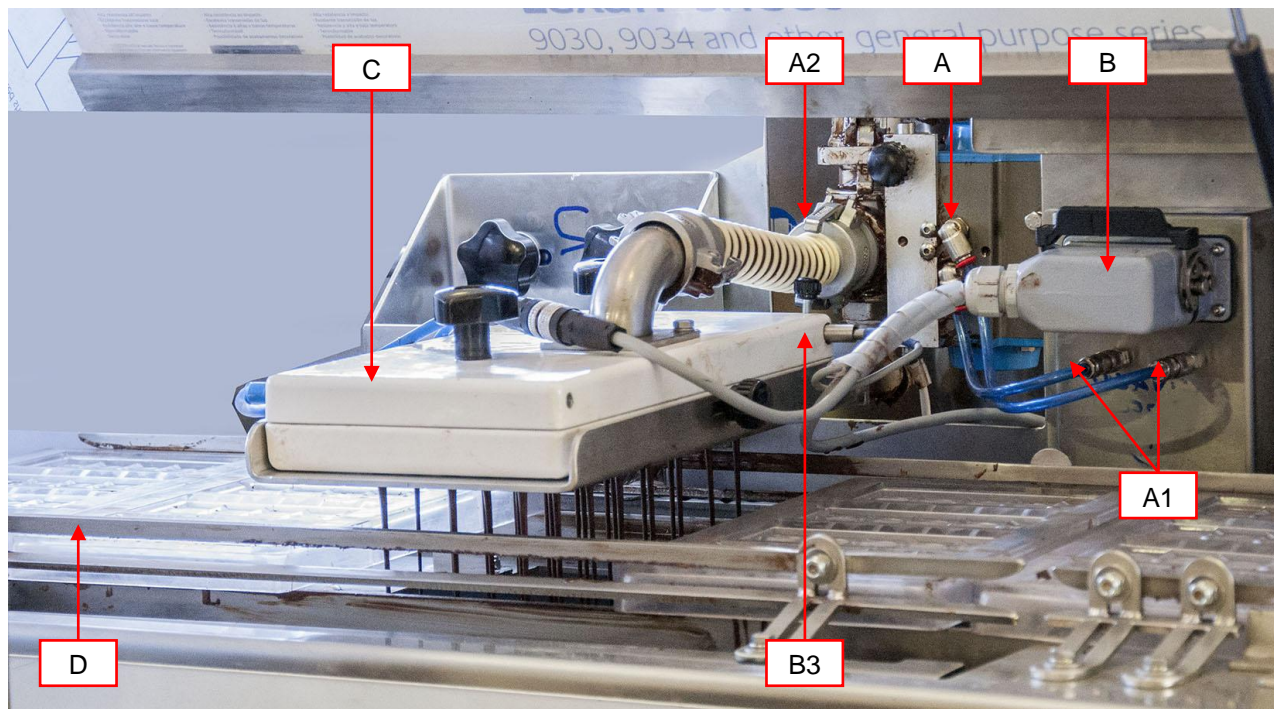

- A. Three ways valve
 1. Compressed air connection
 2. injection head Flexible pipe connection
- B. Alimentation Supply plug:
 1. Three ways valve
 2. Injection head resistances
 3. Injection head probe
- C. Injection head
- D. Mould constrained rails

ROTATION AND VIBRATION AREA

1. Pneumatic motor for the mould 180° rotation
2. Metal frame for to scrape the moulds
3. Vibration motor
4. Pneumatic motor for the mould 180° rotation

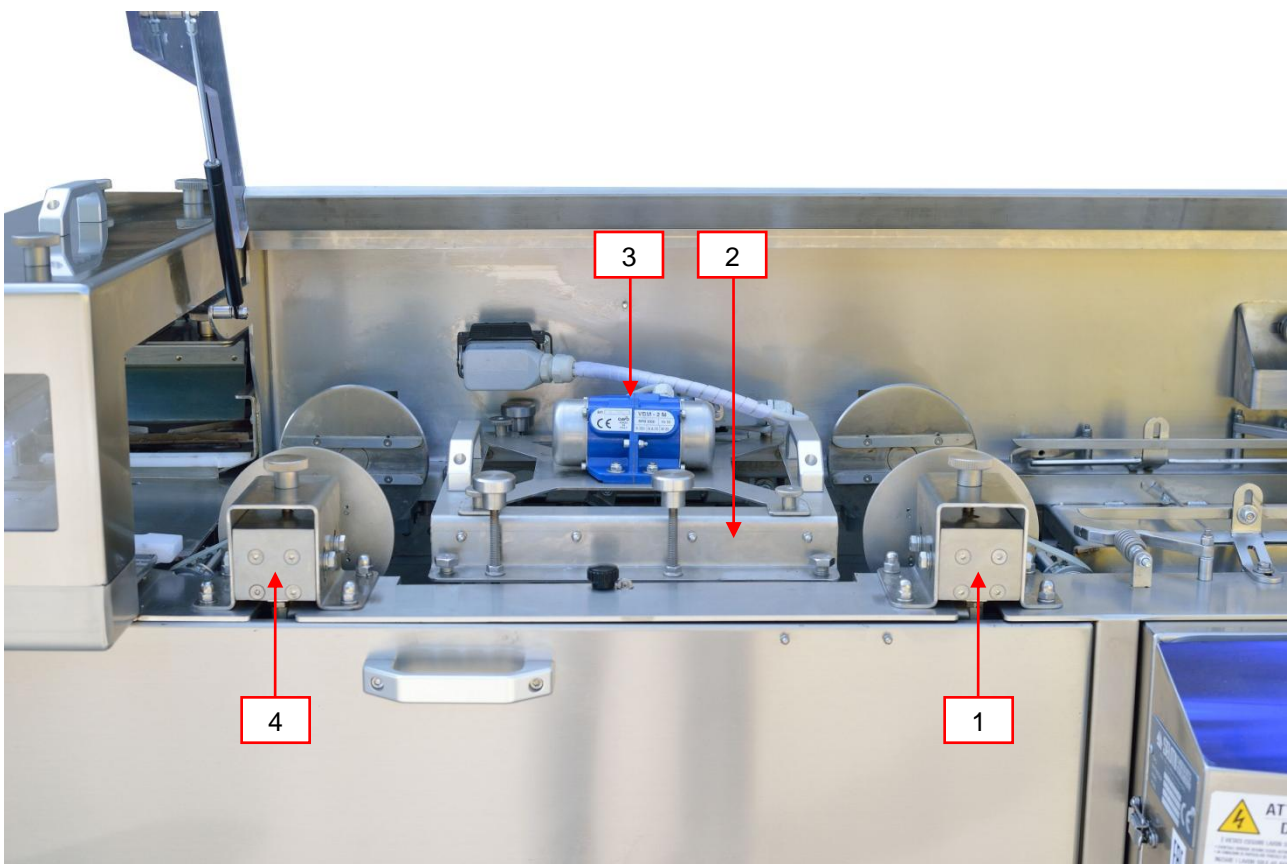

ROTATION AND VIBRATION AREA

1. Scrapers
2. Pneumatic piston for the scrapers movement
3. Final vibration

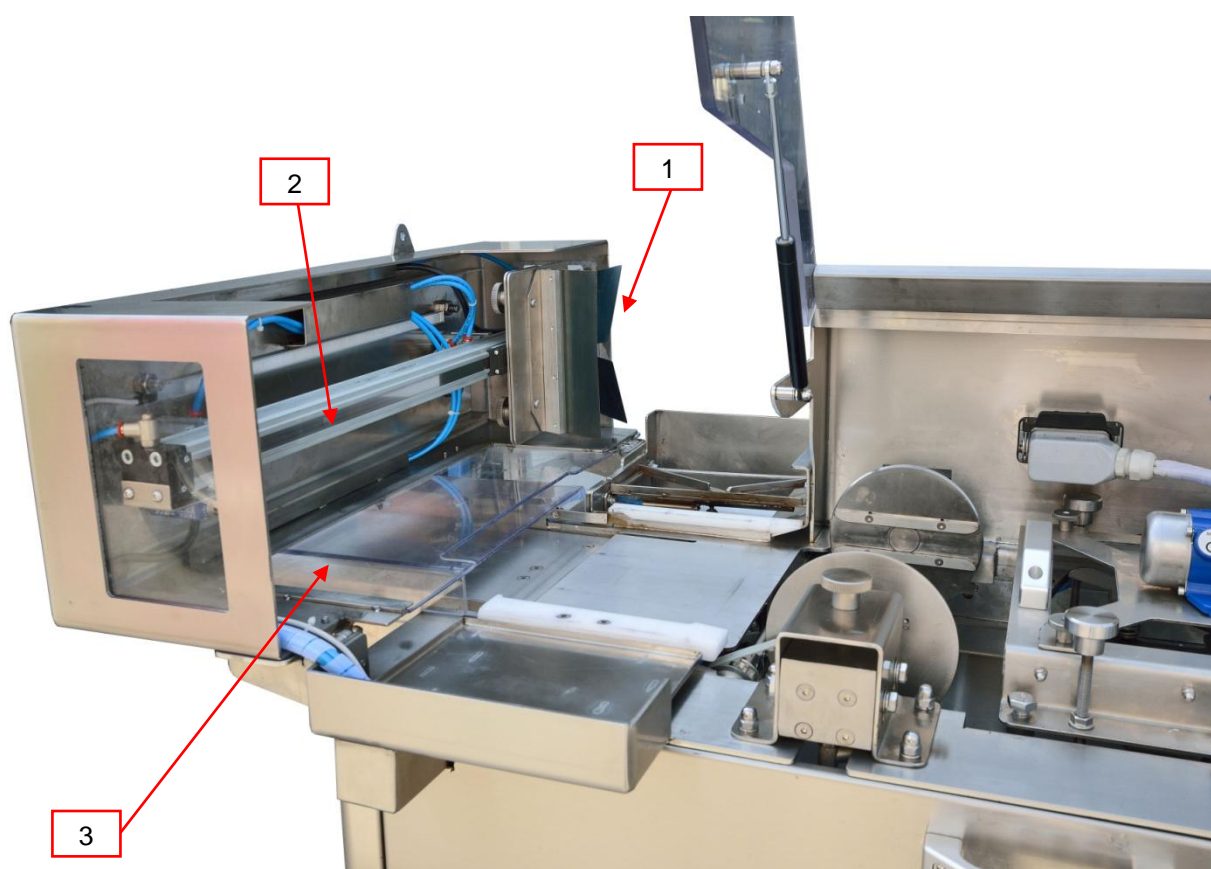

CHOCOLATE RECYCLING

1. Pump for the chocolate recycling to the tempering machine tank
2. Motor and reducer
3. Pipe going into the tempering machine tank
4. Handle for the tank opening (cleaning and maintenance operations)

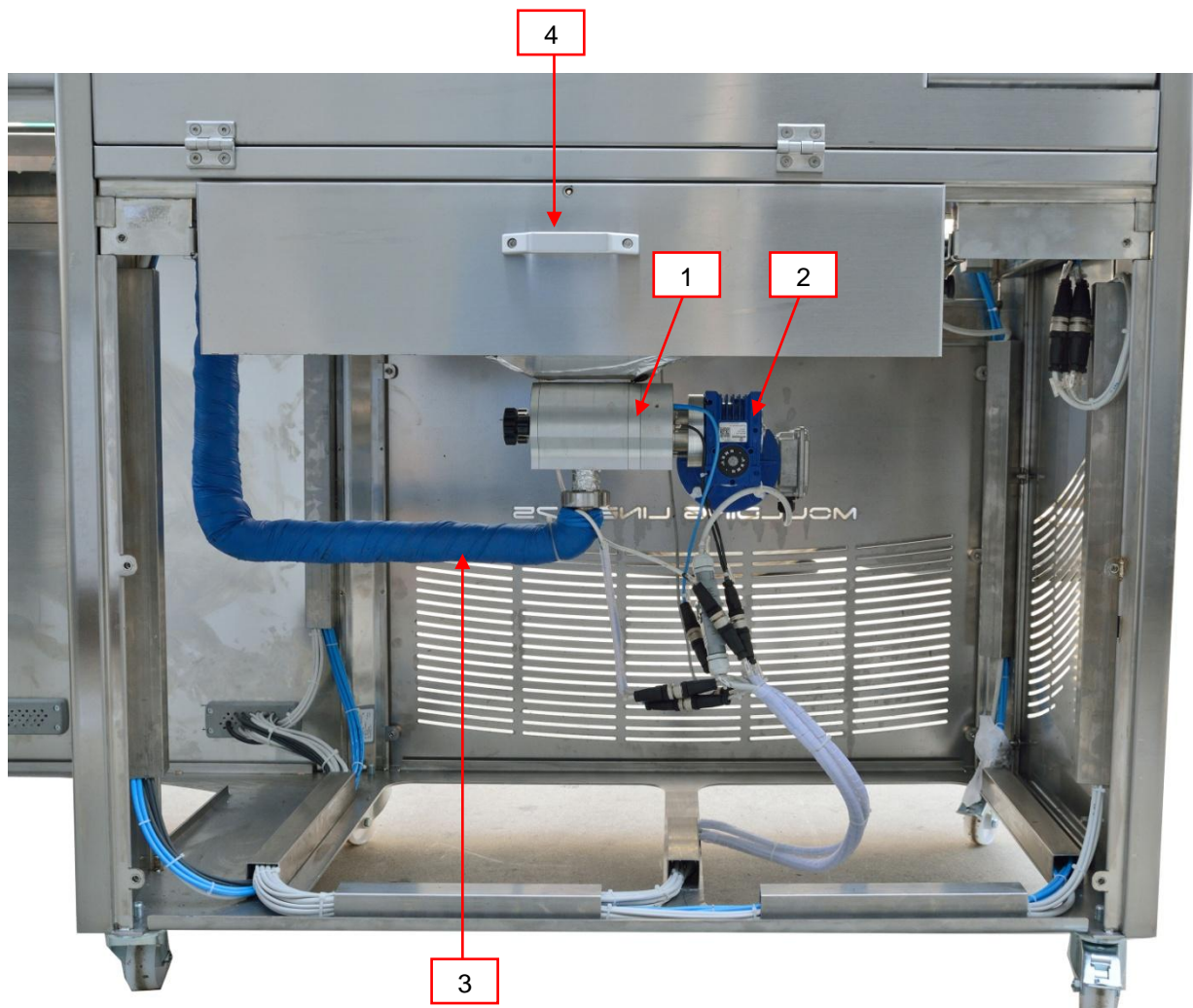

MOULDING LINE 275 back part

1. Pneumatic valve group
2. Air compressed connection
3. Electrical cable
4. Tempering machine position
5. Back protection panel
6. Mould exit point
7. Final scrapers

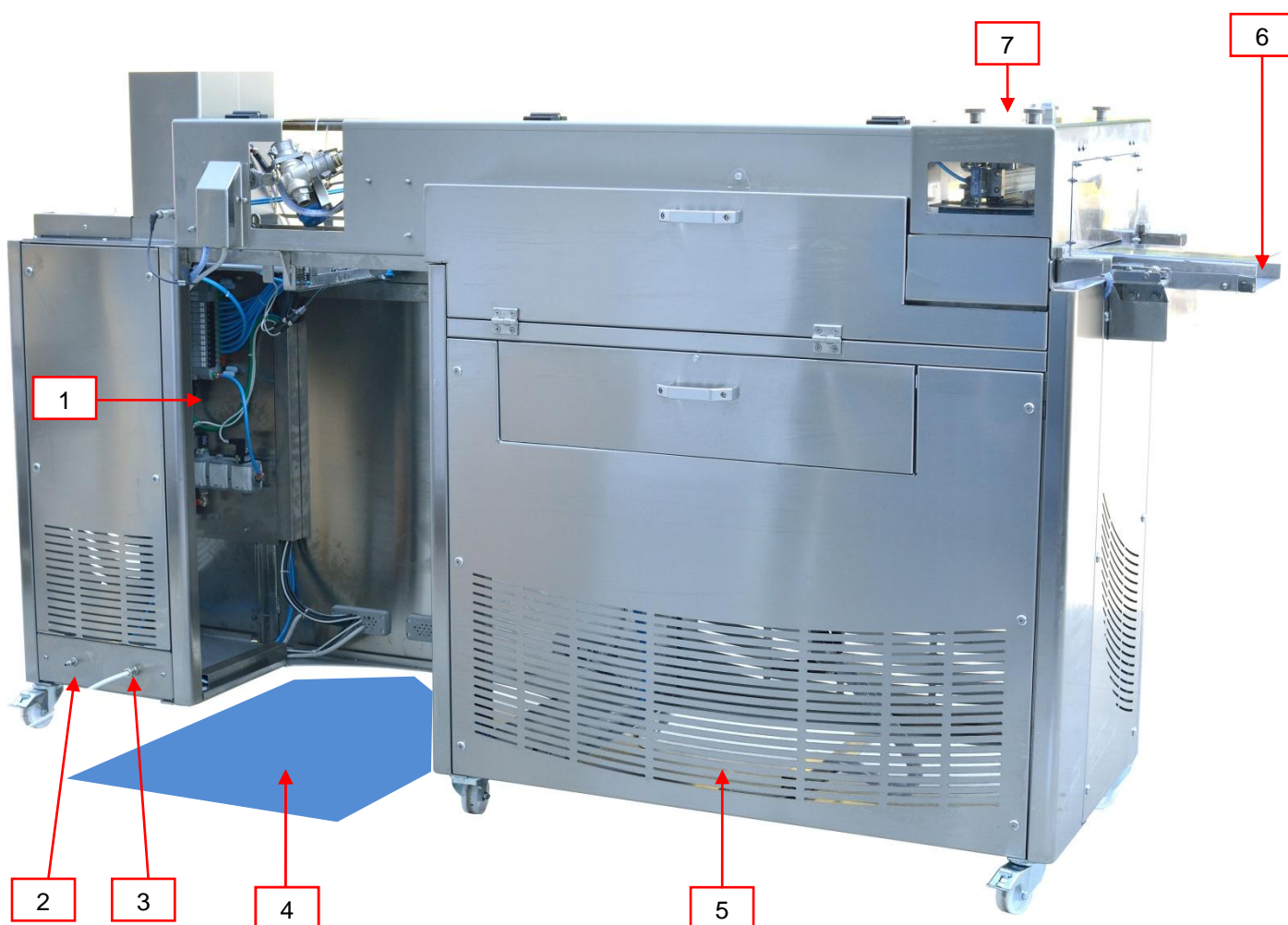

Electrical Panel

- | | | | |
|---|--------------------------------|----|--------------------------------------|
| 1 | Transformer 220 V to 24 V a.c. | 10 | Module for probes |
| 2 | Supply 12V dc Led light | 11 | Module for probes |
| 3 | Socket | 12 | Inverter Pump |
| 4 | Relais resistances | 13 | Inverter vibrator final scraper |
| 5 | Main contactor | 14 | Inverter vibrator rotated moulds |
| 6 | Safety module | 15 | Inverter vibrator filled moulds |
| 7 | 24V d.c. supply | 16 | Clamps |
| 8 | Protection Fuses | 17 | Micro security electrical panel door |
| 9 | Display | | |

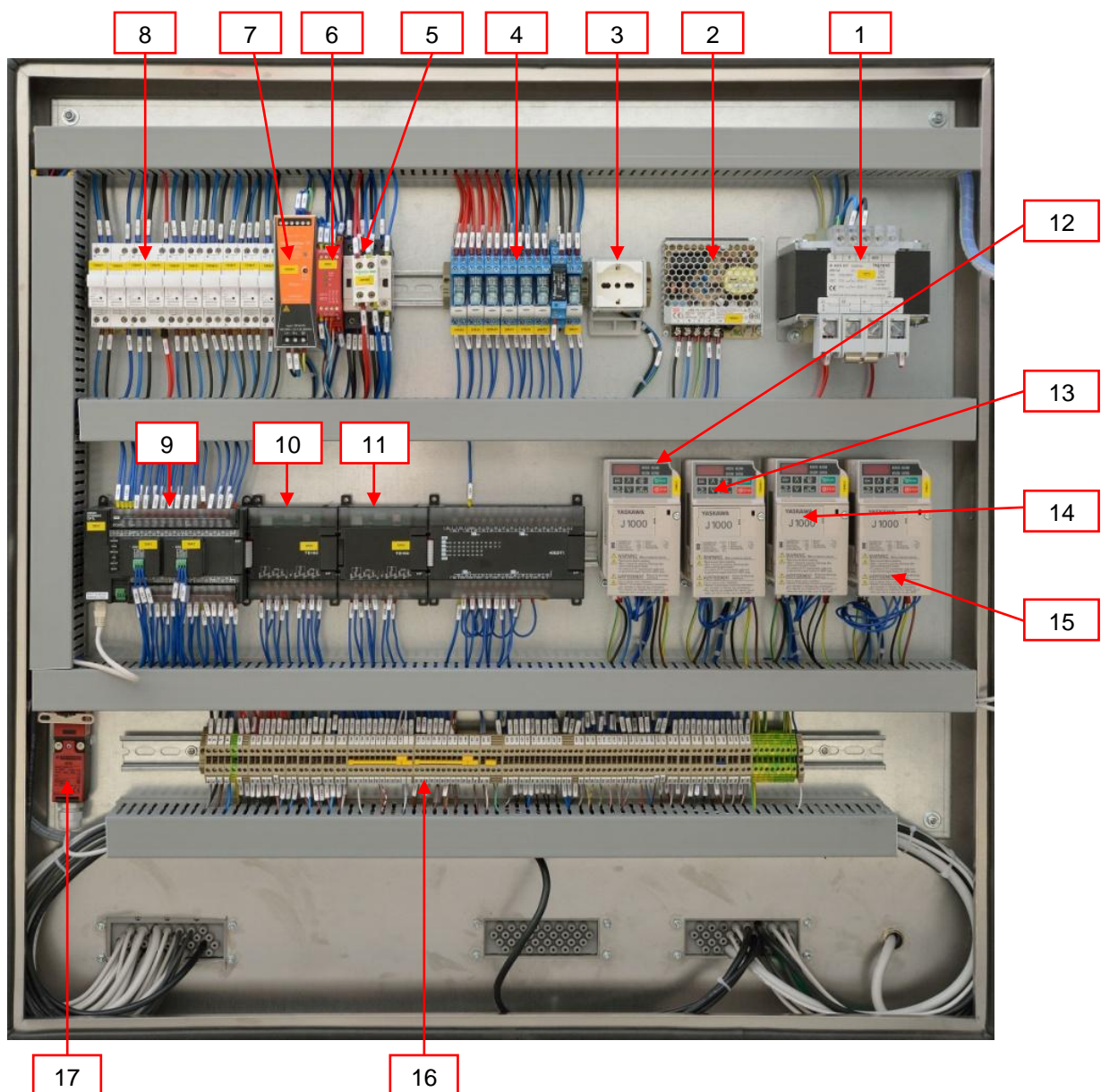

1.7. Details of the manufacturer

The machine described in this instruction manual was built by:

SELMi S.r.l.

Via Statale, 151 – 12069 – S. Vittoria D’Alba (CN) Italia
 Tel. 0172.479273 - 0172.479275 - Fax 0172.477814
 www.selmi-group.it - info@selmi-group.it

1.8. Identification plate of the machine (CE marketing)

There is a plate, similar to the one shown here, on the machine, indicating details of the manufacturer, the CE conformity mark and the machine’s serial number. Always state this number when communicating with the manufacturer.



Example of identification plate on the machine structure

TYPE
SERIAL NUMBER
YEAR
WEIGHT

1.9. Identification plate of the CE marking electric panel (low voltage)

Example of identification plate on electrical panel. For the correct data, see the data shown in the section on the machine’s technical specifications.



1.10. Inteded use

The “MOULDING LINE 275” machine is a continuous tempering machine for chocolate complete with vibrating table. It can be used for the following types of product: plain chocolate, milk chocolate and white chocolate, to perform the tempering operations.

The vibrating table supplied with the machine allows performance of the moulding operations. It is possible to accessorize the machine with further options.

Warning

A use other than that specified is considered improper. The machine is intended for professional use only.

Attention

Do not place any small objects near the control panel or the tank: they could fall and enter the tank, which would contaminate the product.

1.11. Operating environment

To guarantee proper functioning the machine must be protected from atmospheric agents. Its ambient operational temperature should be between 15C° and 35C° with relative humidity not exceeding 70%.

The working environment must be clean, sufficiently illuminated and away from an explosive environment.

The environmental characteristics of the installation site are specified in section 4.

Attention

The machine’s fixed guards have a variety of openings to allow the internal units to cool. When the machine is running, make sure that these openings are not covered by cloths or objects that obstruct proper air flow.

1.12. Noise level

The phonometric tests carried out on this specific machine model show an acoustic pressure lower than 70 dB(A).

1.13. Technical characteristics

Stainless steel:	inox AISI 304 L
Weight:	400 Kg
Programm control:	Digital Display with microprocessor
Electrical characteristics	
Total power installed:	3,5 kW max
Voltage	400 V
Phases	3
Protection	IP65
Compressed air	
Air compressed required	250 l/min
Minimum pressure	6 bar
Air characteristics	Dry disoiled filtered

1.14. Dimensions

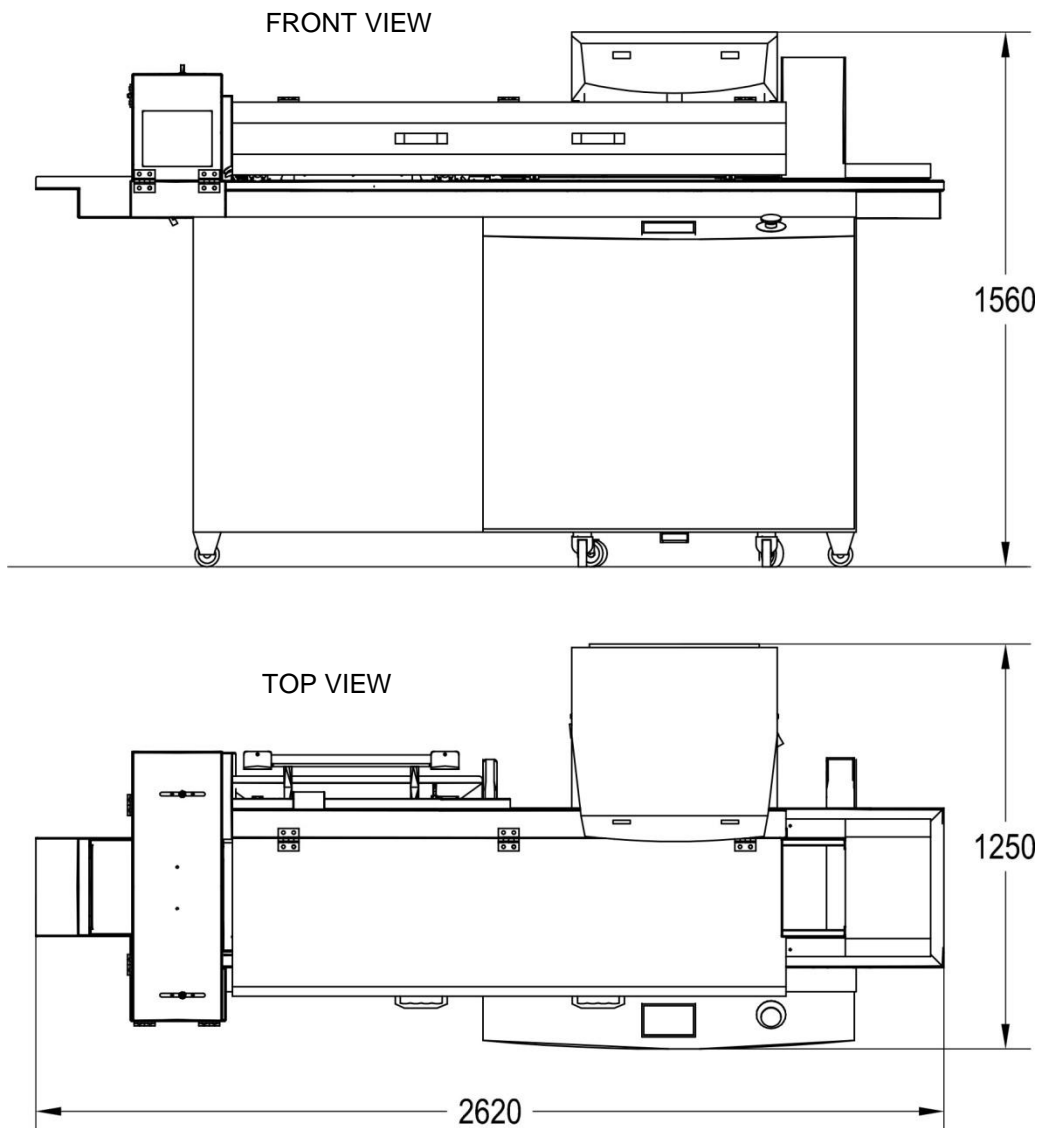

1.15. Storage

Remove the remaining product left in the machine following the instructions in the appropriate section. Stop the machine using the main switch and disconnect it from the electricity main. Move it to a spacious place (it is necessary to work all around the machine).

Clean the tank, the removable components and the pipes.

Attention

It is absolutely necessary to follow the instructions in order to insure the safety of the operators and to avoid damaging the machine's removable parts.

Use a brush to cover the movable components and the mechanical moving parts with a thin layer of food grade lubricant. This can later be removed with an alkaline de-greaser (Sodium Hydroxide) if the machine needs to be re-installed.

Carry out the same operation on the machine surfaces, taking care of avoiding the heating elements located in the inner part of the machine.

Gather the parts (use as reference the delivery packing list) and put them in the original packaging. Place packets of hygroscopic salt based on silica gel in the packaging.

Store all the parts in a sheltered place away from atmospheric agents and in temperatures from 0° C to 40° C. Cover the parts with nylon in order to prevent the accumulation of dust.

1.16. Disposal

Disposal will occur at the end of the working life of the machine, which under normal conditions of use and maintenance will be over ten years.

In the case of disposal all the components of the machine will have to be disposed of in adequate waste yards according to the legislation in force.

Before disposal it will be necessary to separate the plastic or rubber parts and the electrical and electronic material.

Environment

Parts made solely of plastic, aluminium and steel can be recycled in the appropriate collection centres.

According to the RoHS regulations electronic boards and electric material should be recycled separately in authorised collection centres.

1.17. Warranty

The manufacturer offers a warranty on this machine model for a period of 24 months from the purchase date, as shown on the fiscal document issued at the time the machine is delivered.

The warranty will be void if the machine is repaired by a third non authorized party or if fixtures and accessories not supplied by or recommended or approved by the manufacturer are used.

The warranty will also be void upon removal or alteration of the plate showing the serial number and other data.

Within the warranty period the manufacturer will repair or replace, free of charge, parts that are faulty due to manufacturing.

In case the repair has to take place at the manufacturer's site, the machine will have to be sent to the manufacturer in its original packaging.

Transportation expenses will be covered by the manufacturer during the warranty period.

The warranty does not cover the cleaning of the functioning parts.

Defects not clearly attributed to the material or the manufacturing will be examined. If the claim should turn out to be unjustified all repair expenses, changed parts and transportation will be charged to the buyer.

The warranty does not cover damage caused by the following:

- accidental damage during transportation
- damage due to lack of care or procedures carried out incorrectly
- damage due to improper use not conforming to the warnings of the user and service manual
- components subject to wear and tear; a detailed list is available in the components section.

Structural damage, modifications, improper alterations or repairs can affect the functioning of the safety mechanisms, thus making the declaration of conformity and warranty void. Alterations on the machine can be carried out solely by technicians authorised by the manufacturer.

1.18. Professional personnel qualified to operate the machine

The machine must only be used by authorized and purposely trained personnel; the same precautions are also applicable to personnel who carry out maintenance.

Personnel who do routine and extraordinary maintenance must be specially trained professionals; good knowledge of the machine is needed for extraordinary maintenance.

Attention

Do not permit others to approach the machine during its use or maintenance.

The following professional people, after having received all the necessary instructions, are the only ones allowed access to the machine:

Safety officer

The safety officer is responsible for protection and prevention of risks in the workplace, as is mentioned in European Directive 89/391/EEC (Safety in the workplace), introduced in Italy with the 12/11/1994 Legislative Decree.

It is the responsibility of the safety officer to make sure that all personnel who use/maintain the machine have received all the instructions regarding their relative roles contained in this manual.

Operator (user of the machine)

Operator trained and qualified for the use of the machine (working cycle, potential adjustments, etc.). He/she can only carry out the specific tasks described in this manual reserved for this role.

Mechanical maintenance technician

The technician is qualified to use the machine as the OPERATOR and furthermore to use it with the protection disabled, to attend to the mechanical parts for adjustments, maintenance and reparations.

He/she is not qualified to act on live electrical installations.

The mechanical maintenance technician must have a generic knowledge of the machine and a specific knowledge on this machine model.

Electrical maintenance technician

The technician is qualified to use the machine as the OPERATOR and furthermore to use it with the protection disabled, to attend to the adjustments and electrical installations for the purposes of maintenance and repair.

If qualified, he/she may work when the electrical panels, control devices, are live, provided he/she uses appropriate personal protective devices.

The electrical maintenance technician must have a generic understanding of the electrical panels and specific knowledge on the electrical panel and components of this machine.

Manufacturer

The manufacturer's personnel are qualified to perform all of the above-described operations.

Any operations not described in this manual may be performed ONLY by personnel authorized by the manufacturer.

2. Safety section

2.1. Safety information

Attention

The safety officer has the obligation to inform the workers on the risks related to the use of the machine.

Furthermore the employer must inform, educate and train the user according to statutory laws.

The lack of compliance with the basic norms or precautions could result in accidents during the functioning, maintenance or reparations of the machine. Accidents can often be avoided by acknowledging potential hazardous situations before they materialise. The operator must pay attention to the potential dangers and have the training, the competence and the necessary equipment to deal with these tasks correctly.

The manufacturer cannot be held responsible for accidents or damages resulting from the use of the machine by personnel not adequately trained or having used the machine improperly, as well as the lack of, even partial, compliance to the safety norms and interventions procedures contained in this manual.

The safety precautions and the warnings messages, the operator could be subject to accidents with serious consequences for himself and for other people.

In cases where tools, procedures, work methods or working techniques not explicitly suggested by the manufacturer are used, it will be necessary to make sure that no dangers are present for the individual carrying them out and to other alike.



Use exclusively original SELMI spare parts. The manufacturer will take no responsibility for accidents or damages in the case of use of non-original spare parts.

If a tool not supplied by the manufacturer is installed on the machine, the client needs to make sure that the norms stated in Directive 2006/42/EC are adhered to. If this new tool introduces new risks to the system then the new system must be re-certified. In any case the manufacturer cannot be held responsible for accidents or damages caused by the machine if it has been modified or equipped with non original accessories.

2.2. Safety limitations

Attention

The indications mentioned hereafter cannot completely safeguard from all dangers that one might encounter while using the machine; they must be used in conjunction with common sense and the experience of the operator, the only indispensable measures for the prevention of injury.

Every section has a list of specific safety measures for different operations. The safety measures mentioned here below are generic and should be followed for all procedures on the machine.

The responsibilities assigned to specific people concerning the use of the machine must be clearly defined as stated in the "Qualified Personnel" section.

Attention

The use of the machine is forbidden to personnel who have not been authorised or trained by the safety officer.

Consult the manufacturer before carrying out procedures that are not mentioned in this manual.

Prolonged overloads or anomalies can cause the electric motors and electrical appliances to overheat with resultant harmful fumes. In such cases immediately disconnect the machine from the mains and do not approach the machine until such fumes have been dispersed via adequate ventilation. In case of fires do not use water jets on the machine – use CO2 extinguishers instead.

The operator, any helping technician and the maintenance technician must use the appropriate personal protection equipment when working on the machine.

It is forbidden to climb on the machine.

Do not touch the electrical wires, switches, buttons etc. with wet hands.

The parts subject to wear and tear during the functioning of the machine must be checked and replaced as soon as they present noticeable signs of wear and tear.

The manufacturer has designed and built the machine to last for a reasonable time with the Client's normal conditions of use in mind; it is however necessary to periodically check the components and the structure of the machine, paying attention to any anomalous conditions, such as, for example, cracks or deformations. If necessary, contact the manufacturer to ask for a complete check of the machine.

Please consult Section 4 (Installation) for the working environmental conditions of the machine.

2.3. Safety symbols and plaques

The machine has a number of plaques with symbols and and/or safety messages stuck to it.

Attention

Make sure that all the safety messages are legible and in good condition.

Replace the damaged plaques with the new ones from the manufacturer. If a plaque happens to be on a part that is being replaced, make sure that a plaque is present on the new piece.

ATTENTION

THE PERFORMANCE OF WORK ON ELECTRICAL EQUIPMENT CONNECTED TO THE POWER SUPPLY IS STRICTLY FORBIDDEN

- ANY EXCEPTIONS MUST BE AUTHORISED BY THE EXECUTIVE MANAGER
- IN PARTICULARLY DANGEROUS SITUATIONS, ANOTHER PERSON MUST BE PRESENT IN ADDITION TO THE PERSON PERFORMING THE WORK

WORK MAY ONLY BEGIN WHEN THE SAFETY MEASURES HAVE BEEN IMPLEMENTED

IN OBSERVANCE OF PRESIDENTIAL DECREE 543 ON THE PREVENTION OF ACCIDENTS



(positioned on the door of the electrical panel)



Label indicating compulsory reading of the manual
(positioned on the front of the machine)

2.4. Safety and protection devices

Attention

The components shown here are particularly important for the safety of the operator and the machine. In cases of malfunction or wear they must be replaced with spare parts supplied or authorized by the manufacturer.

While the machine is in use all the protection devices must be correctly installed.

The safety devices present on the machine are:

- Mushroom emergency button with mechanical unblock mechanism.



There is an emergency stop mushroom button on the machine. Pushing it cuts voltage to all live parts by means of appropriate devices. To reset it, release the emergency button by turning its head and then push the RESET button shown in the photo.

Before starting every shift, press it to make sure that it works properly.

- *Protective devices*

The machine is equipped with protective plates that can be removed with a tool to allow access to the inside of the machine in order to carry out maintenance operations.

The fixed protective plates are screwed into position and can be removed with the appropriate tool; if the screws are removed the fixed protective plates will not remain in place and must be placed on the floor.

All the protective plates have smoothed and rounded edges for the safety of the exposed individual and of the operators.

The protective plates have loss-proof screws that remain attached to the plate when it is removed from the machine.

Attention

Do not switch the machine on if the protective panels are removed or not correctly fixed into position with the appropriate screws.

Do not forget to remove cloths, keys or utensils used for the maintenance operation from within the machine.

Before closing with the protective panels and switching on the machine check carefully and if necessary remove any extraneous objects which may be present inside the machine.

All protection and safety devices must always be kept in perfect working conditions. If faulty, they must be immediately repaired or replaced.

The replacement, disengagement, partial or total removal of the protective plates, safety devices and protective structures must only be carried out during maintenance operations. This also applies to the safety plaques attached to the side of the machine.

2.5. Client's safety measures

The client must arrange for the following safety measures to be in places:

Provision of an adequate location for installation, paying particular attention to the characteristics below:

- Adequate flooring
- Normal and emergency lighting
- Adequate ventilation
- Clearly signposted emergency exits
- Provision of mains voltage connection with associated safety devices, conforming with the norms in force and the characteristics of the machine
- Adequate means for the collection and subsequent disposal of residues, even hazardous or special ones (oils and grease, broken or waste material, etc.).
- Adequate fire safety systems and equipment
- Prohibition of entry into the installation area to non authorized personnel

The customer must also provide for:

- Training of the operators and the maintenance technicians
- Training for the operators on the basic functioning of the machine and emergency devices
- Provision of personal safety equipment to protect the operator and the hygiene of the product
- Checking the qualifications of external maintenance technicians potentially called to work on the machine
- Keeping of a maintenance log book

The employer is also responsible for checking that the operators correctly carry out the procedures explained in this manual.

2.6. Personal protection equipment

The operators who carry out functions on the machine must receive appropriate instructions on the use of personal protection equipment such as shoes, gloves, etc... which will protect them from residual risks derived from the execution of various activities. The operators must furthermore be equipped with protection equipment for hygiene purposes (caps or hair nets, gown, etc...).

If the noise level in the working environment surpasses 85dB(A) appropriate ear protection must be used.

Warning

The clothing of whoever operates or carries out maintenance on the machine must conform to the essential safety requirements defined by European directive and the laws in force in the country in which the machine is installed.

Attention

During maintenance operations individuals must wear adequate clothing to prevent the occurrence of accidents.

In order to avoid mechanical risks such as snagging or dragging, it is prohibited to wear particular objects such as bracelets, watches, rings or necklaces during the working cycle and during maintenance operations.

2.7. Residual risks

The accurate risk analysis carried out by the manufacturer and archived in the technical file has eliminated most of the residual risks, which are nevertheless present during the use of the machine, to acceptable levels.

The manufacturer's recommendation is to meticulously adhere to the instructions, procedures and recommendations contained in this manual.

Attention

It is strictly prohibited to carry out any type of mechanical or electrical modification so as not to create added dangers and unforeseen risks.

Attention

During cleaning and maintenance operations and during the work cycle, do not allow the product inside the tank to come into contact with water or other fluids.

Attention

If the machine remains unused for long periods of time please take note of the expiry date of the product remaining inside the machine. Upon restarting the processing only insert new chocolate if the product already in the machine has not expired. If the old product has expired, proceed to empty and clean the machine before inserting the new product.

Attention

Keep the machine with the residual chocolate inside the tank in an adequate environment with temperatures ranging from 10 °C to 25 °C.

The residual risks present on the machine are:

Risks during machine transportation

It is recommended to fasten the machine, or its parts, at the dedicated locations and lift it with appropriate means to the minimum permitted height, proceed at low speeds and make sure that the people helping with the moving are at a safe distance from the moving object. Before moving the machine make sure that the passage is clear and that there are no objects placed on the machine. It is important that the means of support and transportation is controlled by a person qualified for such a role, so as to avoid unforeseen movements which may be dangerous to the people in the vicinity who are helping with the moving.

Risks of faults to the circuits of signalling, safety, protection and emergency stop

In the case of a circuit fault, the safety and signaling circuits, the anti-injury protections and the emergency stop can lose their effectiveness, therefore it is asked that their functionality is periodically checked.

Identified residual risks and information plaques

The manufacturer has placed on the machine danger and/or warning plaques, based on the residual risks, with pictograms in compliance with the norm pertaining to the display of graphic symbols on the machine.

The user should immediately replace these plaques if they are not clearly legible.

Attention

It is expressly forbidden to remove the safety and/or warning plaques placed on the machine. The manufacturer will not take any responsibility on the safety of the machines if this is not observed.

Risk to life (electrocution)

Before commencing work on any electrical appliance it is necessary to disconnect the machine from the mains. If it were to become necessary to work within the electric panel by bypassing the electricity cut off devices, then the work must be carried out exclusively by specialized personnel.

Risk of spreading fire

In case of fire never use jets of water in the vicinity of the apparatus. Disconnect all connections to the mains and use the appropriate CO2 extinguishers located in the building.

2.8. Applied Directives

The following directives apply to the machine described in this manual:

- 2006/42/EC machinery Directive
- 2014/30/UE Directive for electromagnetic compatibility
- 2014/35/UE low voltage Directive

And the regulation:

- 1935/2004 EC regulation for materials in contact with foodstuffs

2.9. Harmonized technical norms

The machine was designed and tested to conform to the "essential requirements to health and safety" present in attachment I of European Directive 2006/42/EC.

The norms used as reference for the design, the realization and the testing of the machine are listed in the technical file archived by the manufacturer.

3. Moving and transportation section

3.1. General norms

Before moving the machine always check the weight and general instructions shown on the packaging. Personnel not responsible for the movement of the machine must not remain in the area needed for movement.

3.2. Packaging

The machine is delivered on a platform, secured by means of straps and placed inside a cardboard packaging which is also secured to the platform by means of straps. An example of the machine packaging is shown in the picture below.

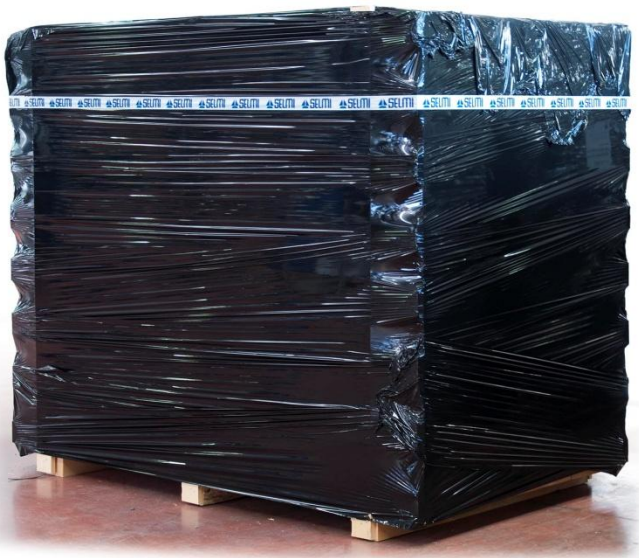

Instructions for transportation are on the sides of the packaging.

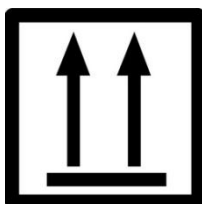

The first symbol shows the correct upright position of the packaging;



the second symbol shows that the packaging must be protected from the rain;



the third symbol shows that the content of the packaging is fragile and must be handled with care. On two sides of the packaging there is a device called "TILTWATCH", which can determine if the packaging has been tilted to such an extent that the content may have been damaged; it is necessary to pay attention to the instructions given on the adhesive label. If the machine has been excessively tilted during transportation (the dot at the centre of the TILTWATCH device will be red) some components could have been damaged.



Attention

The manufacturer's warranty does not cover damage during transportation; the buyer should follow the instructions on the adhesive label in order to avoid disputes.

3.3. Transportation

To transport the machine it is necessary to use a suitable vehicle equipped with a platform to lift the load; the platform must be adequate for the weight of the machine, which is stated in the technical characteristics section (section 1.13).

When the machine, still in its packaging, is in the body of the lorry, it can be carried to the lifting platform only by means of a manual transportation trolley for euro pallets.

The lifting platform has to be equipped with side rails in order to prevent the machine from falling when it is still high off the ground.

The machine can be lowered to the ground from the platform only after having lowered the manual trolley.

The machine should be lowered slowly from the platform, avoiding shaking and sudden stops which could cause a loss of stability.

After having completed the unloading procedures, the machine should be moved exclusively by means of a manual transportation trolley adequate for euro pallets; the platform should only be lifted to the height needed to move the machine.

Before moving the machine verify that the passage to the final destination is clear.

Attention

Do not go on very steep ramps which could cause the loss of control of the trolley.

3.4. Removal of the packaging

Cut the straps that anchor the cardboard to the platform; remove the cardboard and put it out of the way.

Cut the straps that hold the machine to the platform, remove the machine's plastic cover and unravel the accessories provided.

Carefully lift the front of the machine and remove the wooden slat blocking the front wheels; subsequently remove also the wooden slat blocking the rear wheels by lifting the back of the machine.

Very carefully lower the machine from the platform.

Note

Keep the original packaging; it may be necessary to use it if the machine needs to be sent to the manufacturer for extraordinary maintenance or repairs.

4. Installation section

4.1. Positioning

Warning

Before positioning the machine check that the machine, the associated accessories and the parts supplied separately have not been damaged during transportation.

It is the task of the Client to make sure that the strength of the supporting surface, at the point of installation, is adequate for the weight of the machine.

The flooring at the point of installation must be sufficiently level.

Isolate the machine from any potential vibrations coming from other nearby machinery.

In the case where the machine or any of the associated accessories are found damaged it is important to alert the manufacturer of the found anomaly so as to agree on the actions to be taken.

Attention

The machine must be placed on a level surface; for the other environmental requirements necessary for optimal functioning of the machine please see sections 1.11 and 2.5..

4.2. Electrical connections

Attention

The connection of the machine to the electrical system must be carried out by personnel observing the legislation in force; the characteristics of the electrical connection must be compatible with the electrical specifications of the machine which can be found in the relevant section or on the opposite plaque on the door of the electric panel.

Attention

If the machine has been purchased to be powered by a three phase line, make sure that in the socket there is a connection to the neutral wire. This is necessary for the functioning of the machine.

Attention

Before starting any procedure make sure that there are no objects inside the tank.

5 - OPERATION SECTION

Starting page

Language selection

JOG button

Pressing Jog you can test and verify all the singles components of the machine: pistons, resistances, pump, electro valves, vibrating engines, etc.

This function can be useful when something is not working to understand the cause of problems, when the machine is not working properly.

WORK button

Goes to the working page



Working page

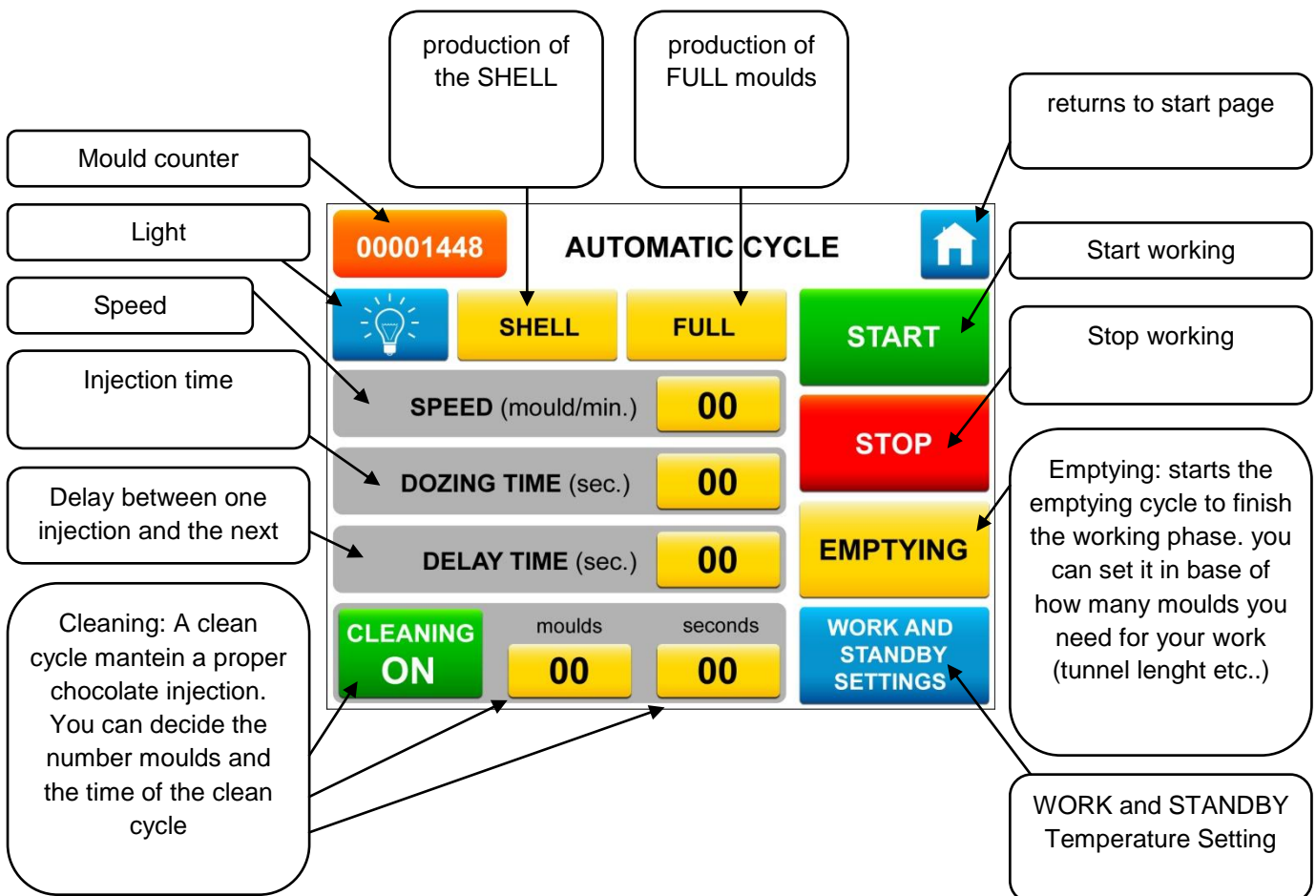

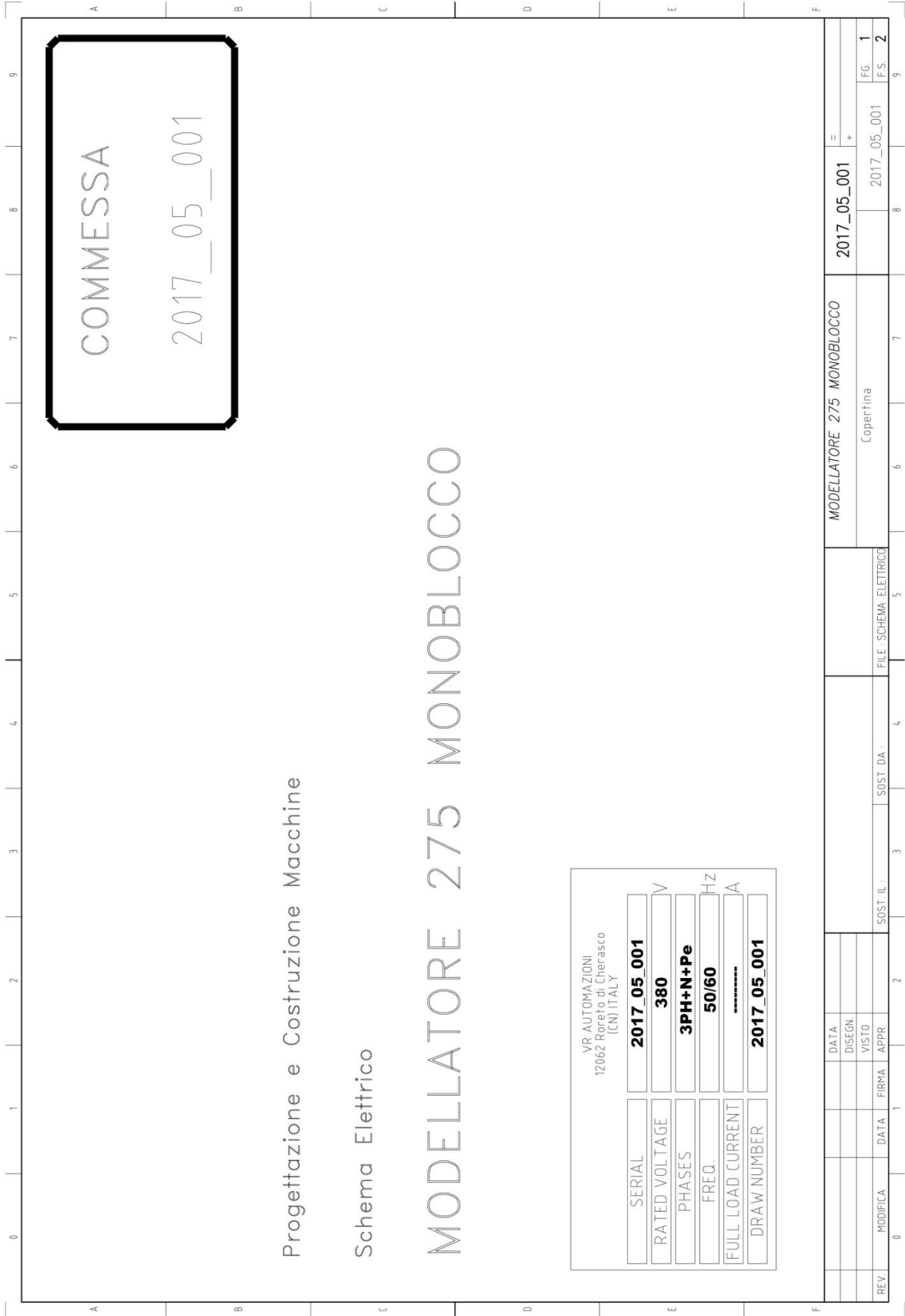

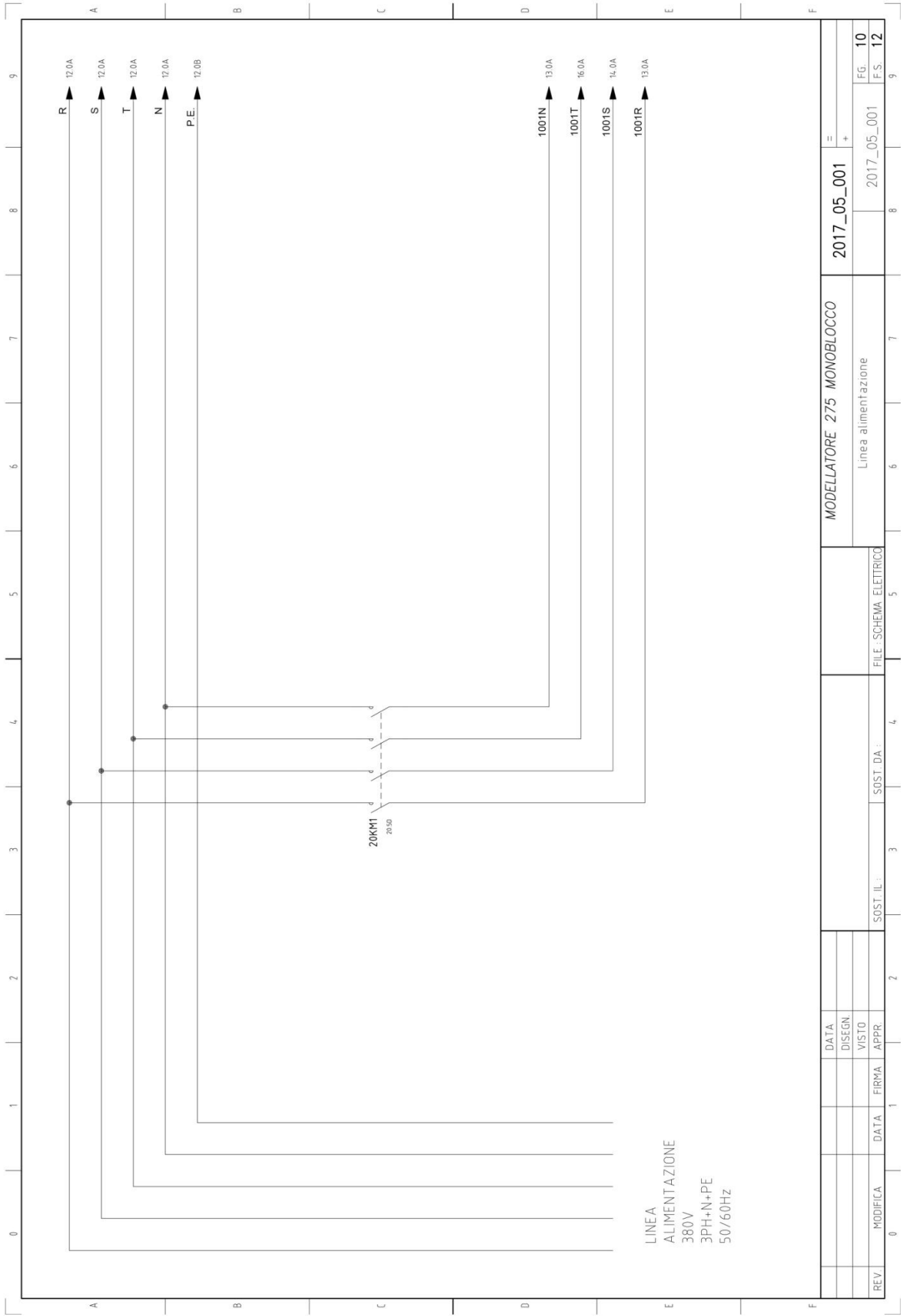

MODELLO		2017_05_001		=	
DESCRIZIONE		Linea alimentazione		+	
REV.	MODIFICA	DATA	FIRMA	APPR.	
SOST. IL :			SOST. DA :		
FILE : SCHEMA ELETTRICO					
MODELLO		2017_05_001		FG. 10	
				F.S. 12	

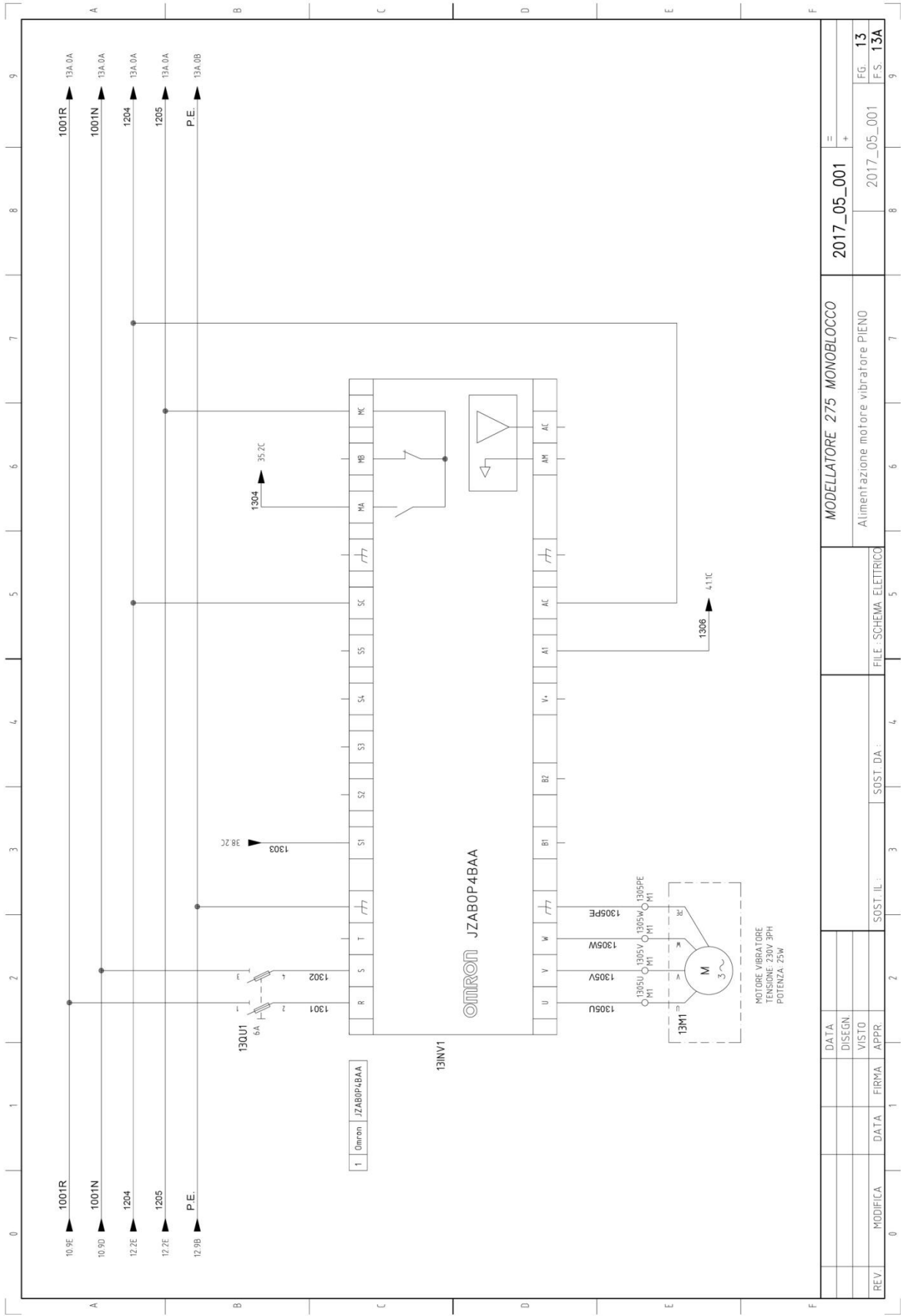

REV	MODIFICA	DATA	FIRMA	APPR.	SOST. IL :	SOST. DA :	FILE - SCHEMA ELETTRICO	MODELLATORE 275 MONOBLOCCO	2017_05_001	=	+
								Alimentazione motore vibratore PIENO	2017_05_001		
											FG. 13
											F.S. 13A

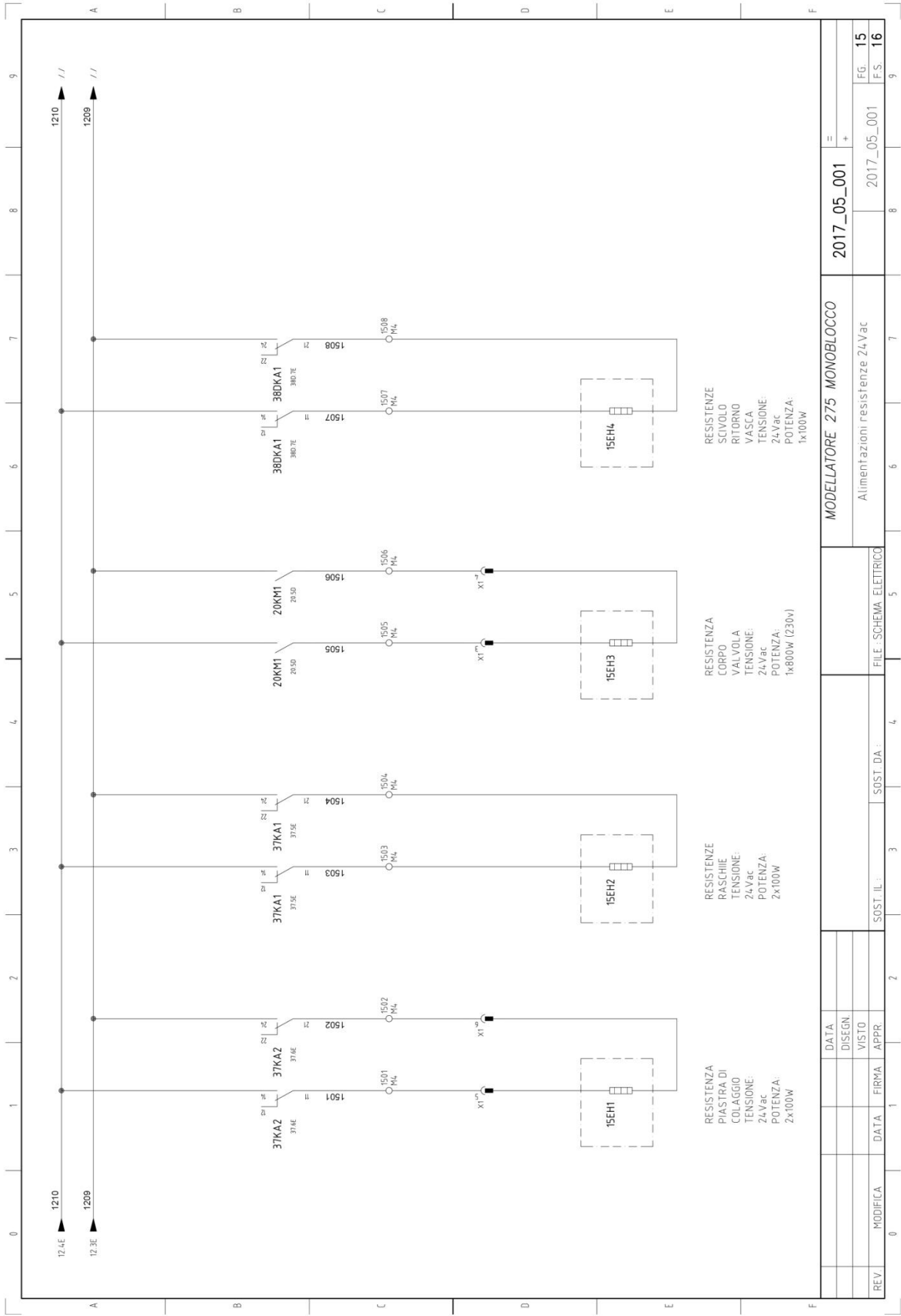

REV		MODIFICA	DATA	FIRMA	APPR.	VISTO	DISEGN.	DATA
SOST. IL :		SOST. DA :		FILE : SCHEMA ELETTRICO				
MODELLATORE 275 MONOBLOCCO								
Alimentazioni resistenze 24 Vac								
2017_05_001								
							=	
							+	
							2017_05_001	
							FG. 15	
							F.S. 16	

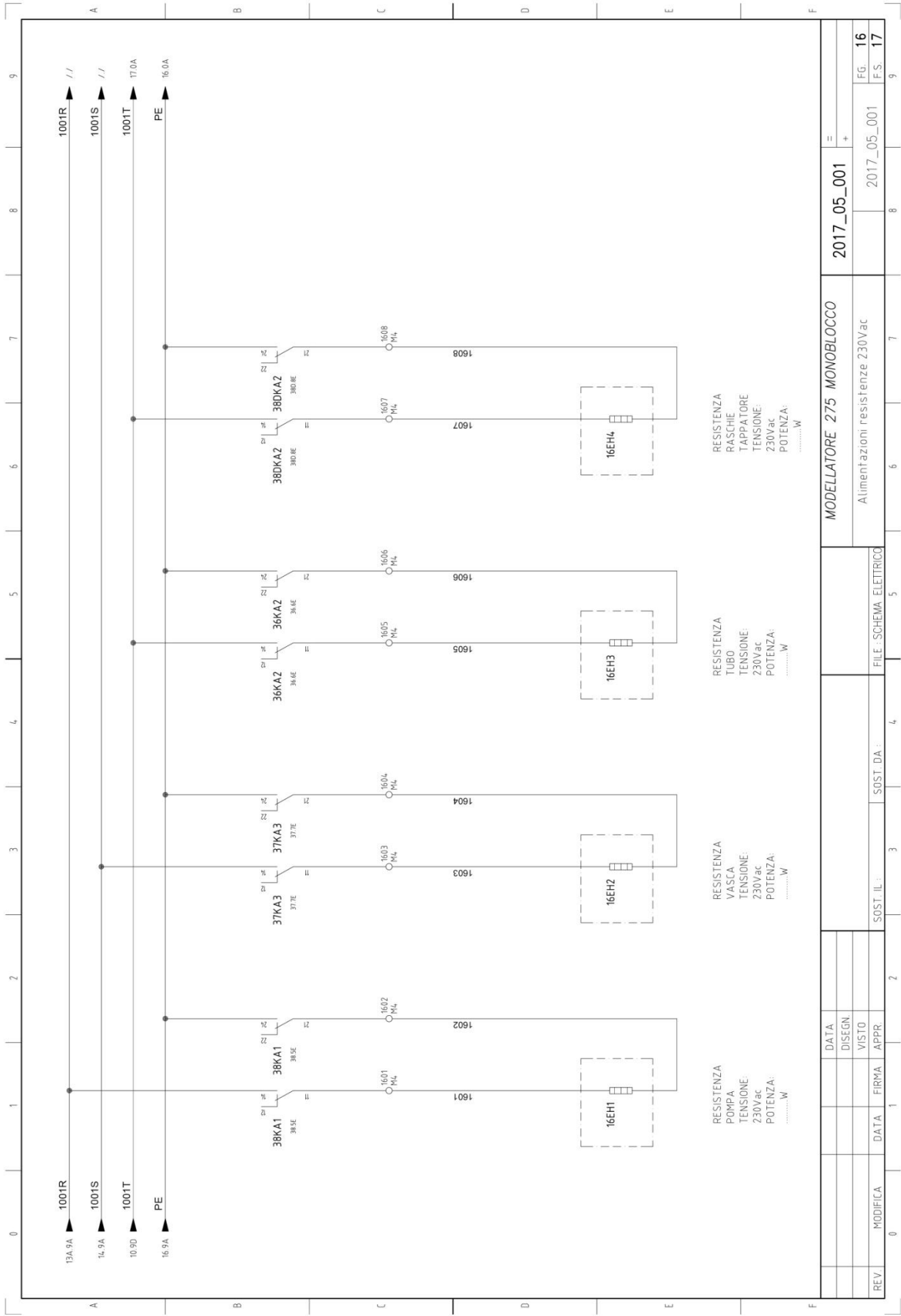

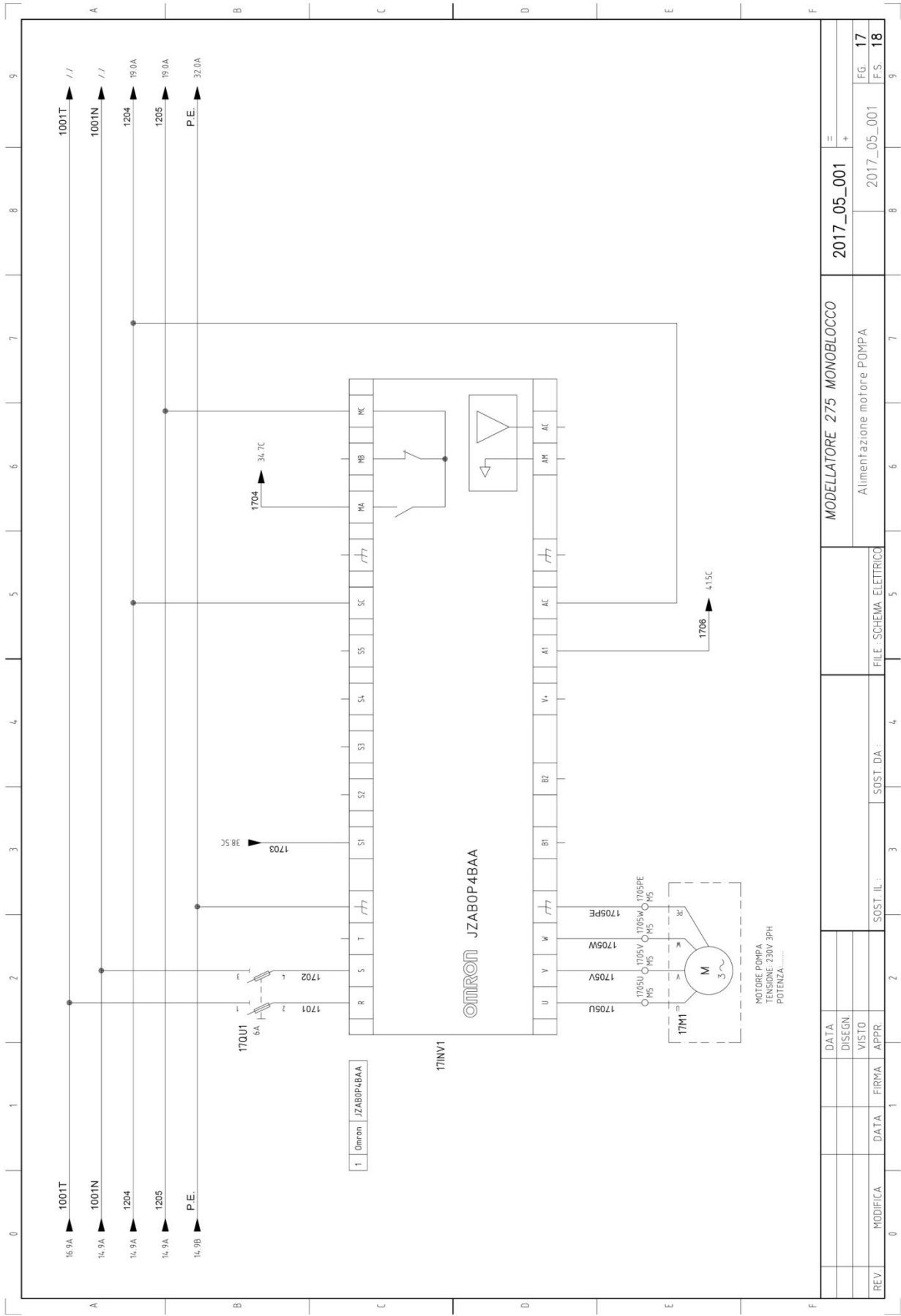

REV	MODIFICA	DATA	FIRMA	APPR.	VISTO	DESIGN.	DATA	SOST. IL :	SOST. DA :	FILE - SCHEMA ELETTRICO	MODELLORE 275 MONOBLOCCO	Alimentazione motore POMPA	2017_05_001	+	FG. 17
															F.S. 18

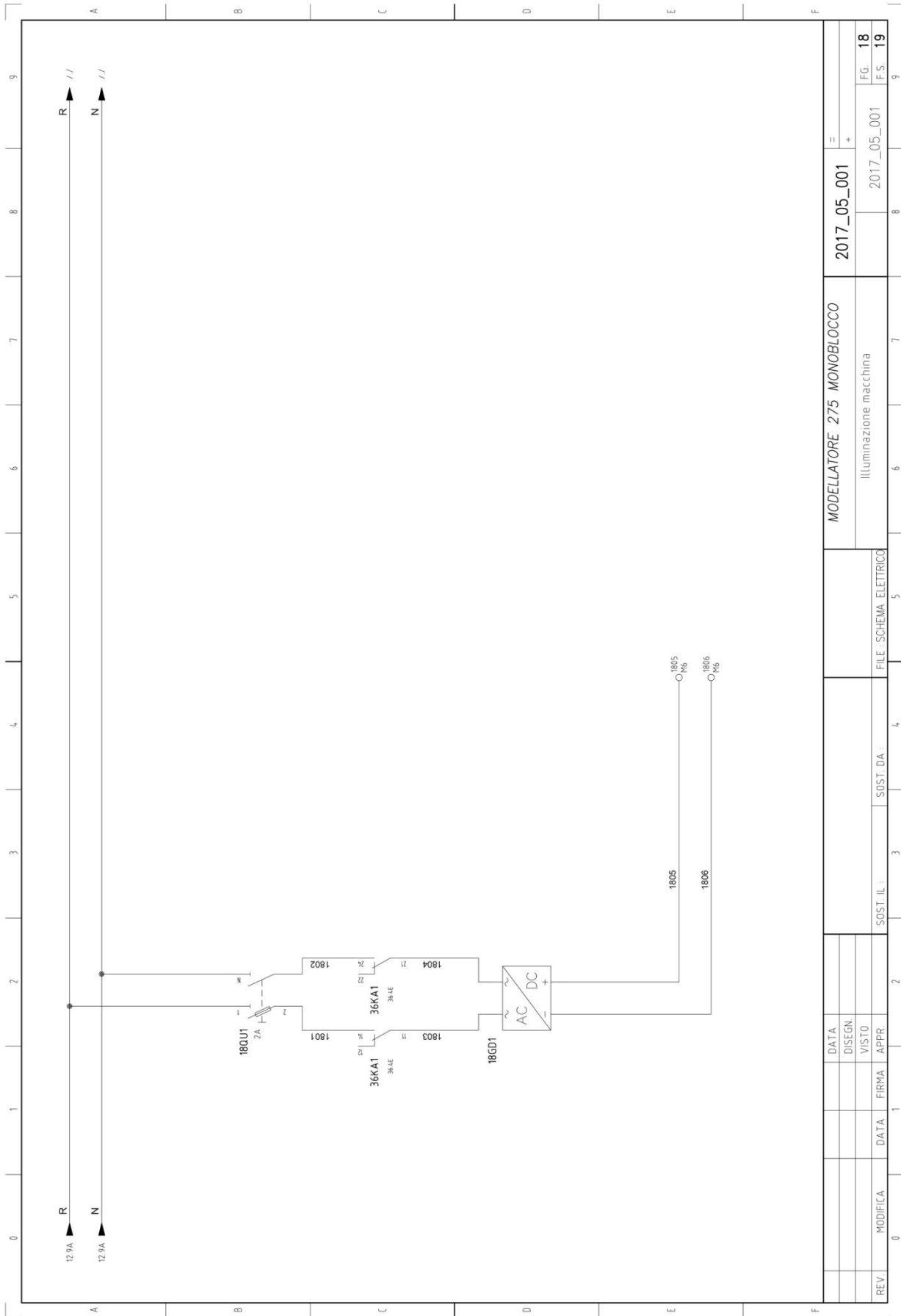

REV	MODIFICA	DATA	FIRMA	APPR.	SPST. IL :	SPST. DA :	FILE _SCHEMA ELETTRICO	MODELLATORE 275 MONOBLOCCO	2017_05_001	=	FG. 18
							illuminazione macchina		2017_05_001	+	F.S. 19

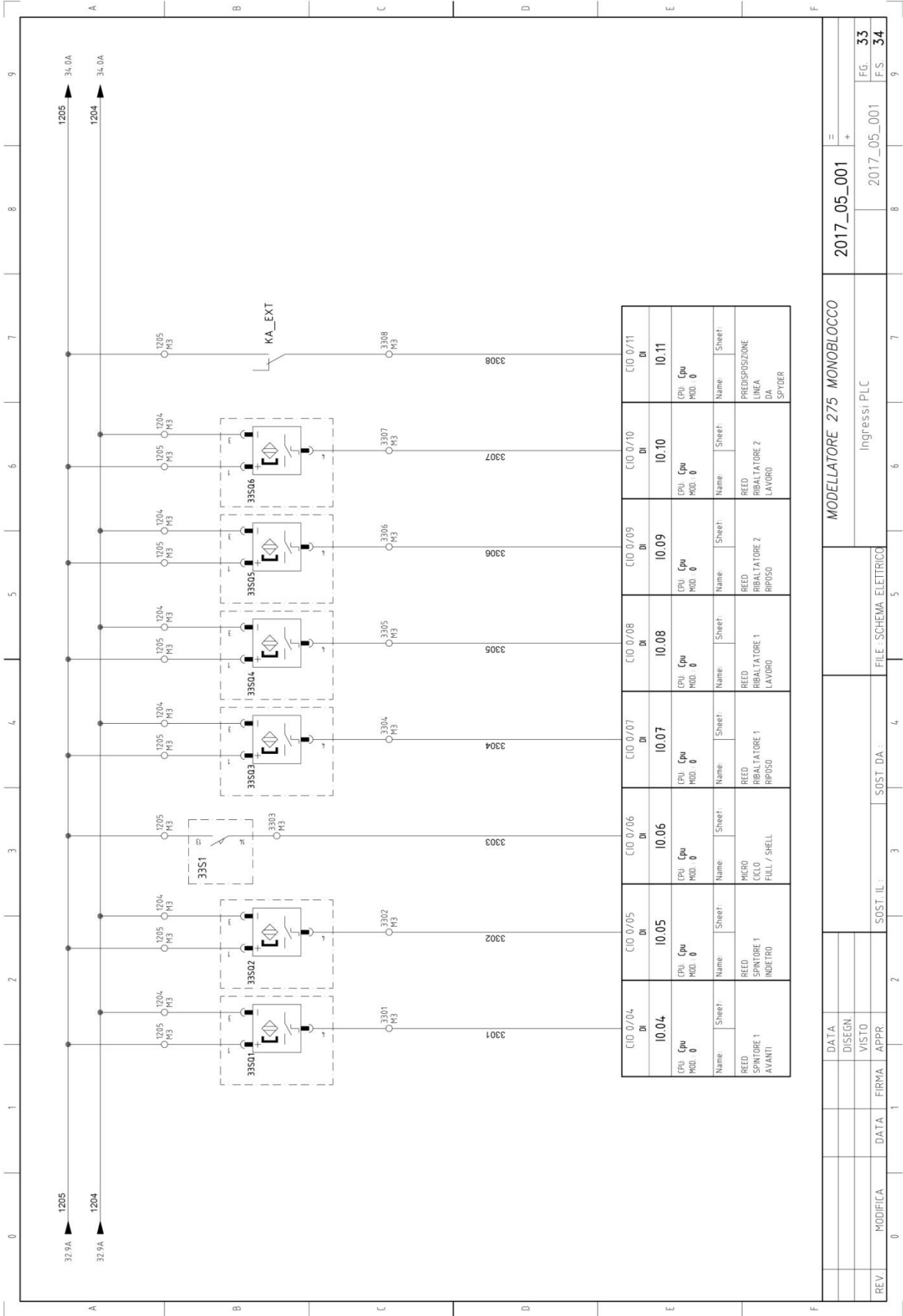

CIO 0/04	CIO 0/05	CIO 0/06	CIO 0/07	CIO 0/08	CIO 0/09	CIO 0/10	CIO 0/11
DI	DI	DI	DI	DI	DI	DI	DI
10.04	10.05	10.06	10.07	10.08	10.09	10.10	10.11
CPU MOD. 0	CPU MOD. 0	CPU MOD. 0	CPU MOD. 0	CPU MOD. 0	CPU MOD. 0	CPU MOD. 0	CPU MOD. 0
Name: REED SPINTORE 1 AVANTI	Name: REED SPINTORE 1 INDIETRO	Name: MICRO CICLO FULL / SHELL	Name: REED RIBALTATORE 1 RIPOSO	Name: REED RIBALTATORE 1 LAVORO	Name: REED RIBALTATORE 2 RIPOSO	Name: REED RIBALTATORE 2 LAVORO	Name: PREDISPOSIZIONE LINEA DIA SPYDER
Sheet: 3301 M3	Sheet: 3302 M3	Sheet: 3303 M3	Sheet: 3304 M3	Sheet: 3305 M3	Sheet: 3306 M3	Sheet: 3307 M3	Sheet: 3308 M3

DATA									
DISegn.									
VISto									
FIRMA									
APPR.									
SOST. IL :									
SOST. DA :									
FILE : SCHEMA ELETTRICO									
MODELLORE 275 MONOBLOCCO							2017_05_001		
Ingressi PLC							2017_05_001		
							FG. 33		
							F.S. 34		

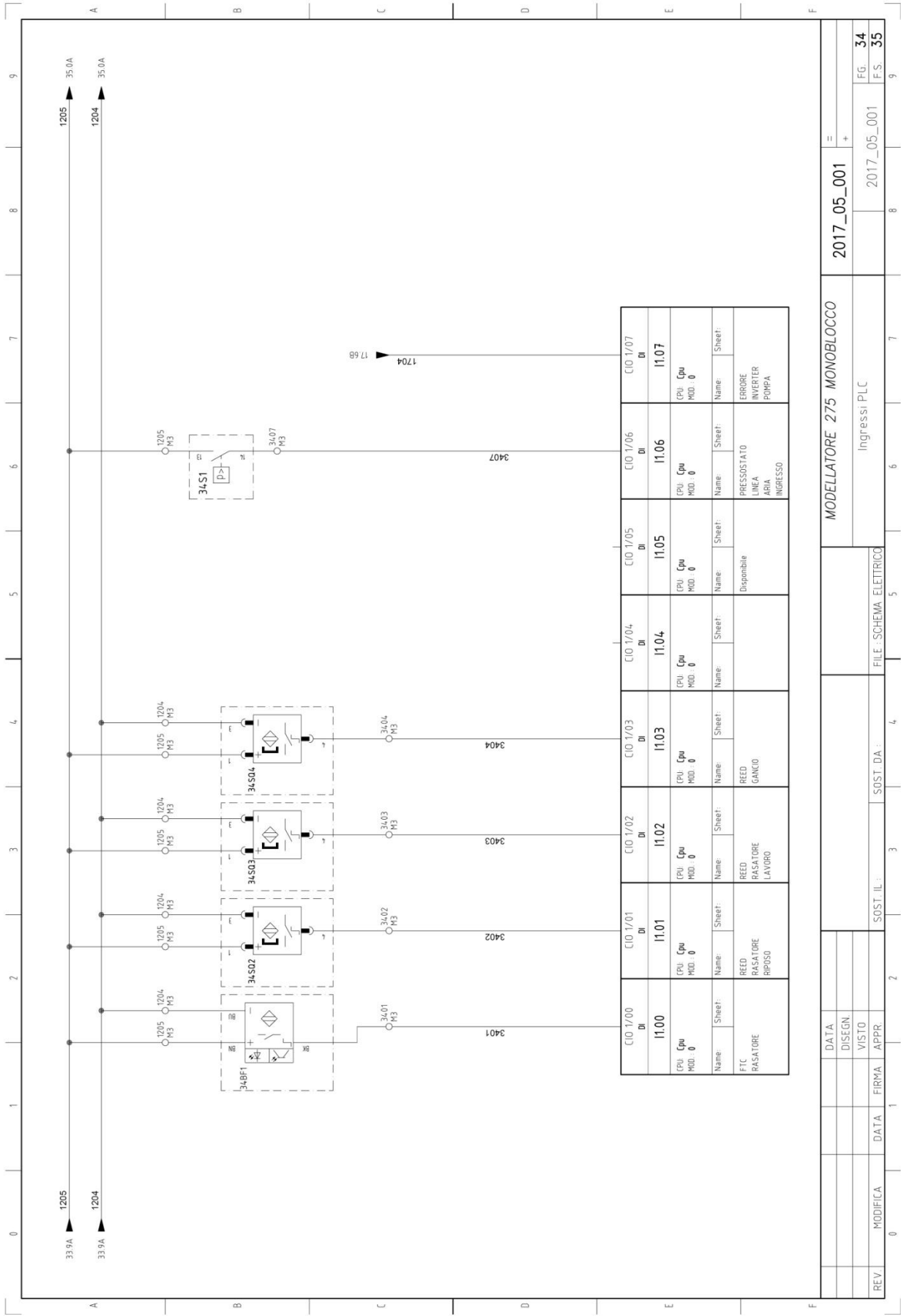

DATA									
DISIGN.									
VISTO									
FIRMA									
DATA									
APPR.									
SOST. IL :									
SOST. DA :									
FILE - SCHEMA ELETTRICO									
MODELLO 275 MONOBLOCCO							2017_05_001	=	
Ingressi PLC							2017_05_001	+	
REV	MODIFICA							FG.	34
								F.S.	35

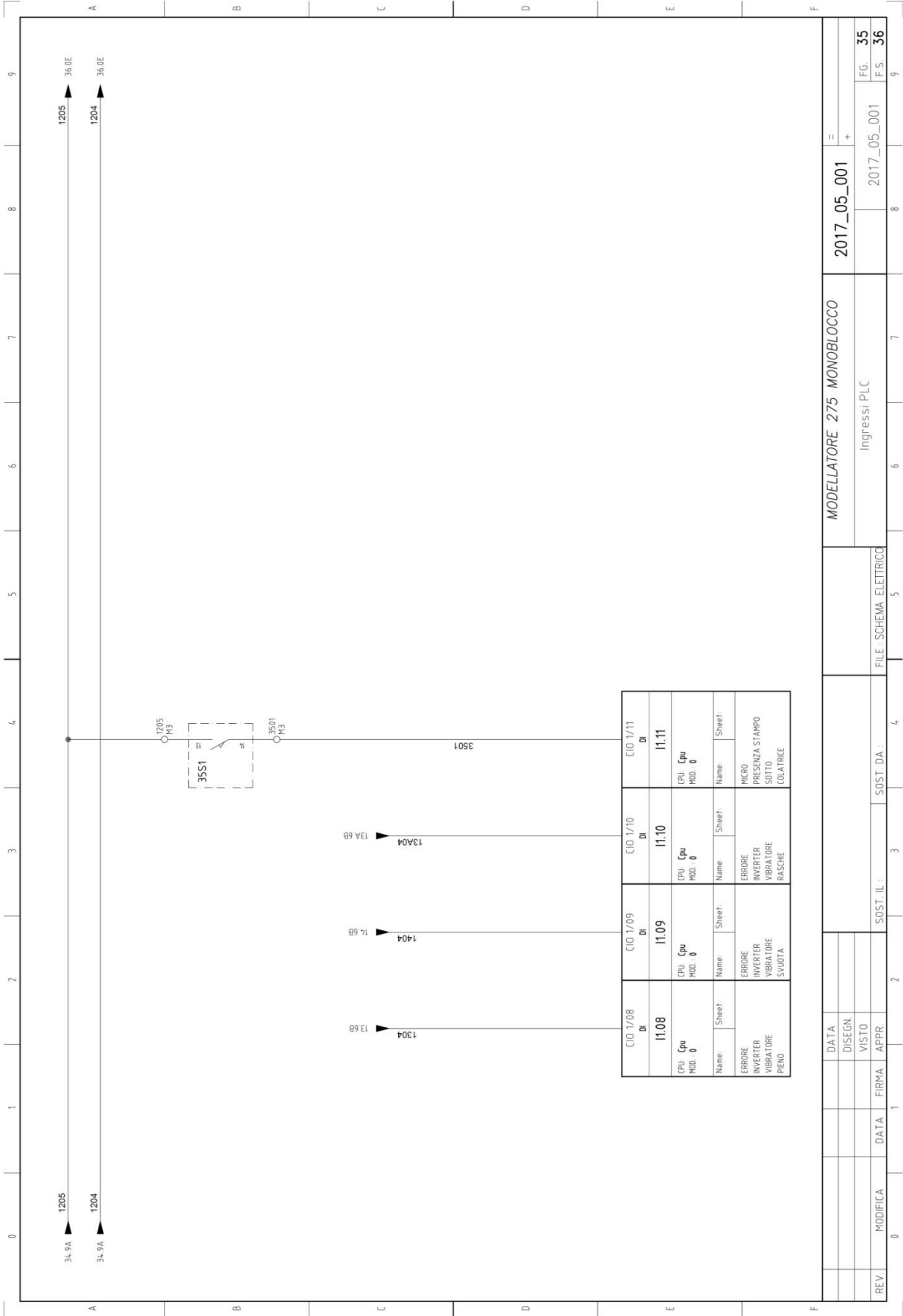

REV	MODIFICA	DATA	FIRMA	APPR.	SOST. IL :	SOST. DA :

FILE - SCHEMA ELETTRICO	MODELLO	2017_05_001	+
Ingressi PLC	MODELLO	2017_05_001	+

FG.	F.S.
35	36

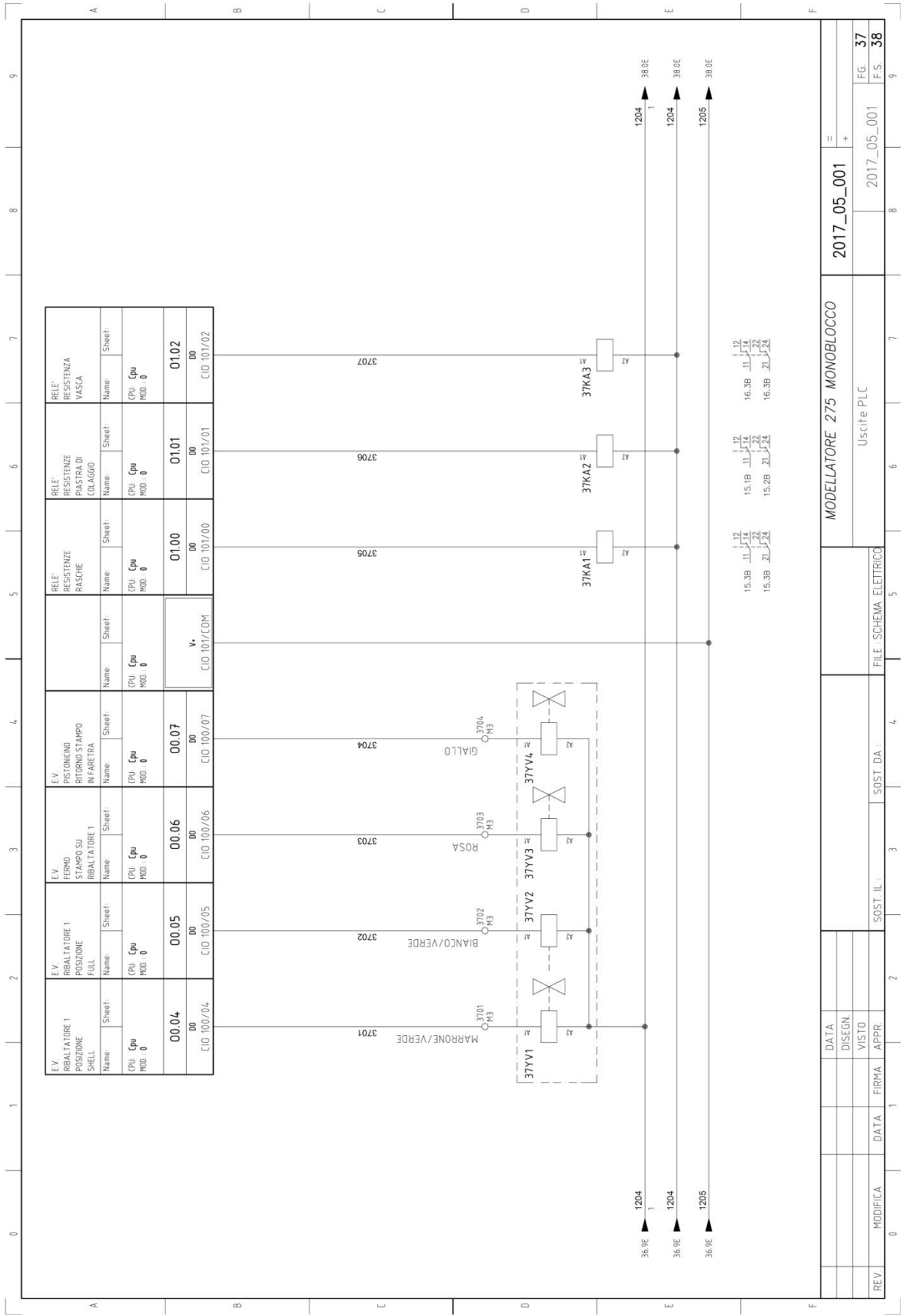

REV	MODIFICA	DATA	FIRMA	APPR.	SOST. IL :	SOST. DA :	FILE - SCHEMA ELETTRICO
							MODELATORE 275 MONOBLOCCO
							2017_05_001
							Uscite PLC
							2017_05_001
							FG. 37
							F.S. 38

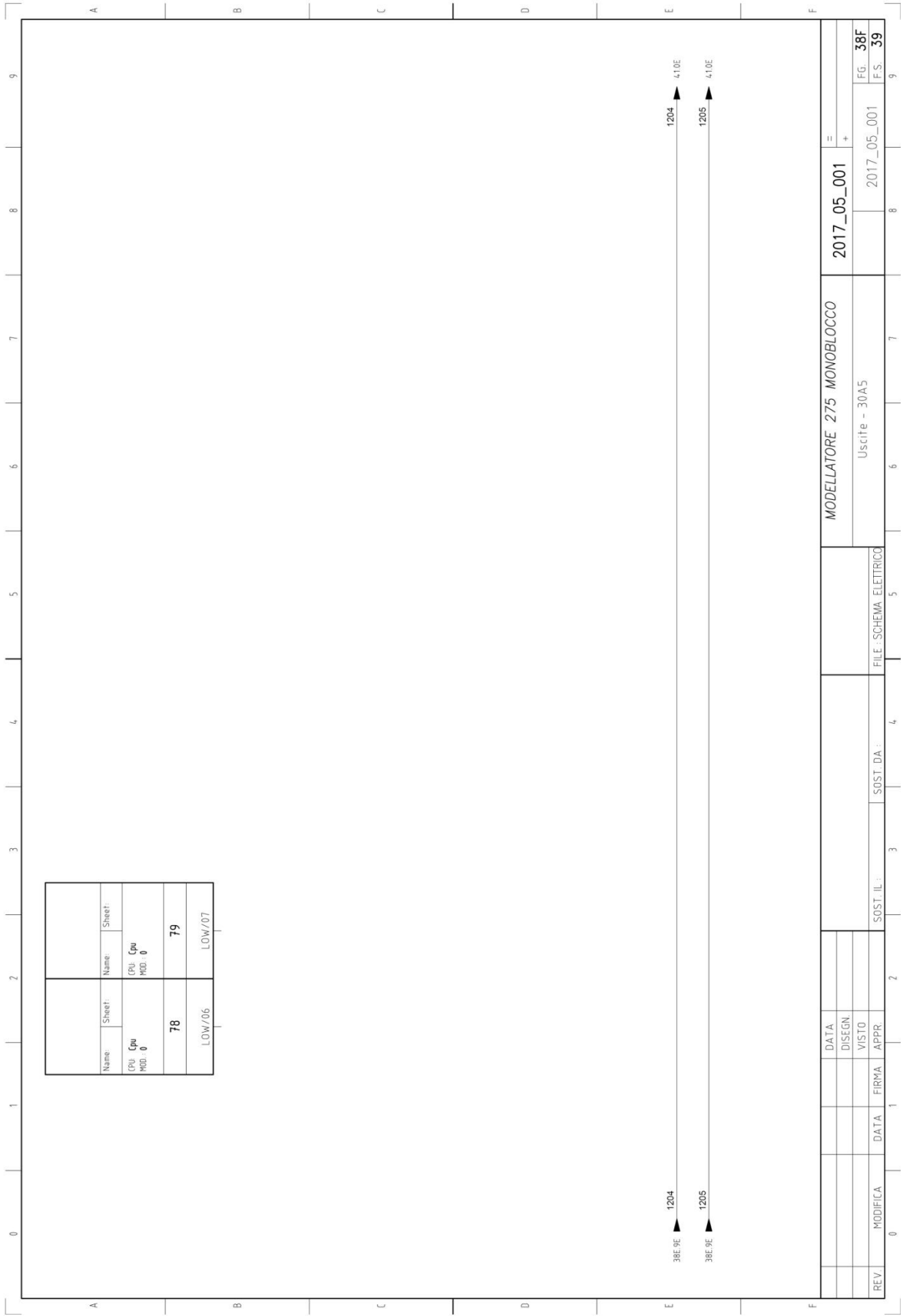

Name	Sheet	Name	Sheet
Cpu MOD. 0		Cpu MOD. 0	
78	LOW/06	79	LOW/07

REV	MODIFICA	DATA	FIRMA	APPR.	SOST. IL :	SOST. DA :	FILE - SCHEMA ELETTRICO

MODELLORE 275 MONOBLOCCO		2017_05_001	=
Uscite - 30A5		2017_05_001	+

FG. 38F
F.S. 39

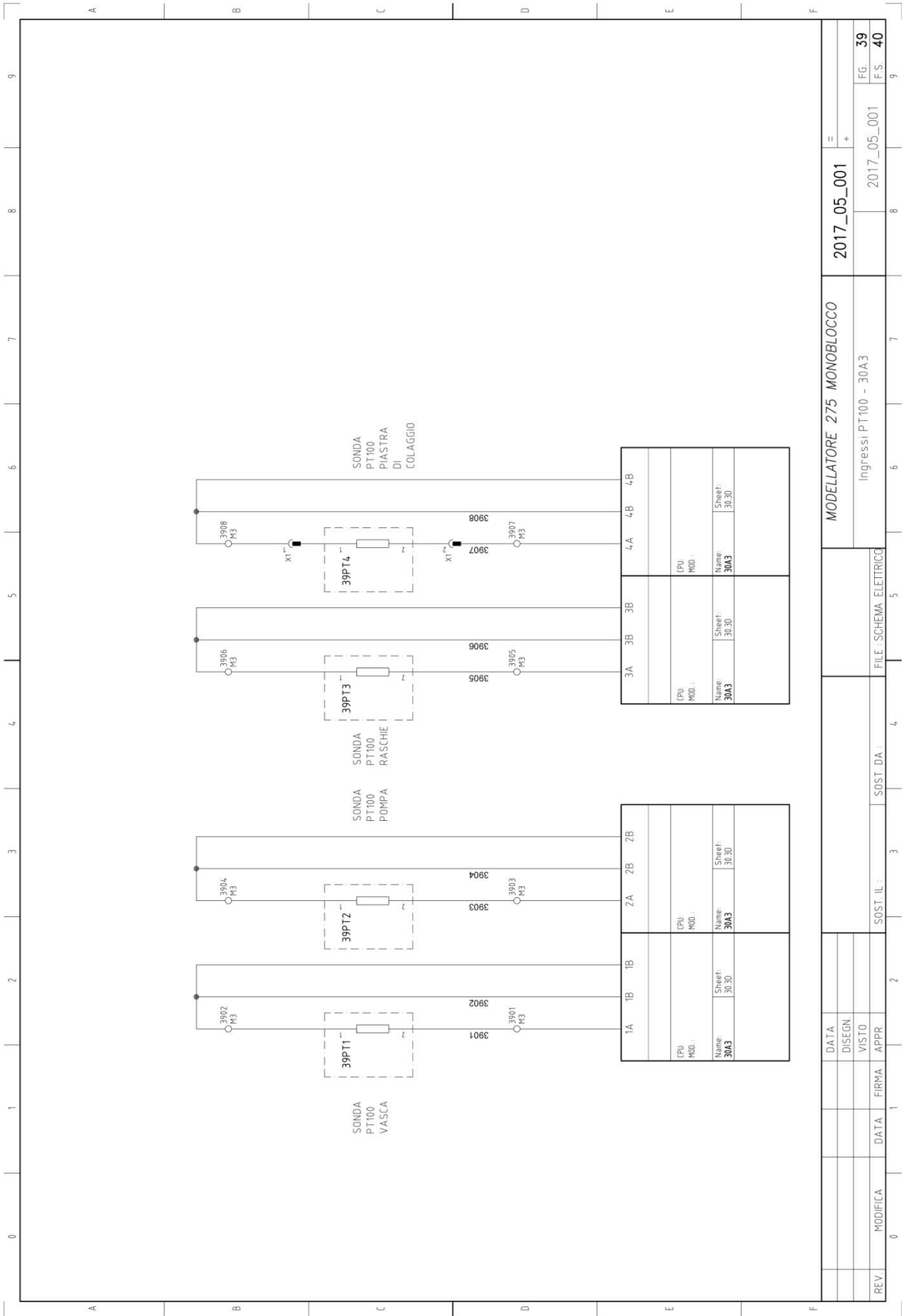

REV	MODIFICA	DATA	FIRMA	APPR.	SOST. IL :	SOST. DA :	FILE : SCHEMA ELETTRICO	MODELLORE 275 MONOBLOCCO	2017_05_001	=	+
								Ingressi PT100 - 30A3	2017_05_001		
											FG. 39
											F.S. 40

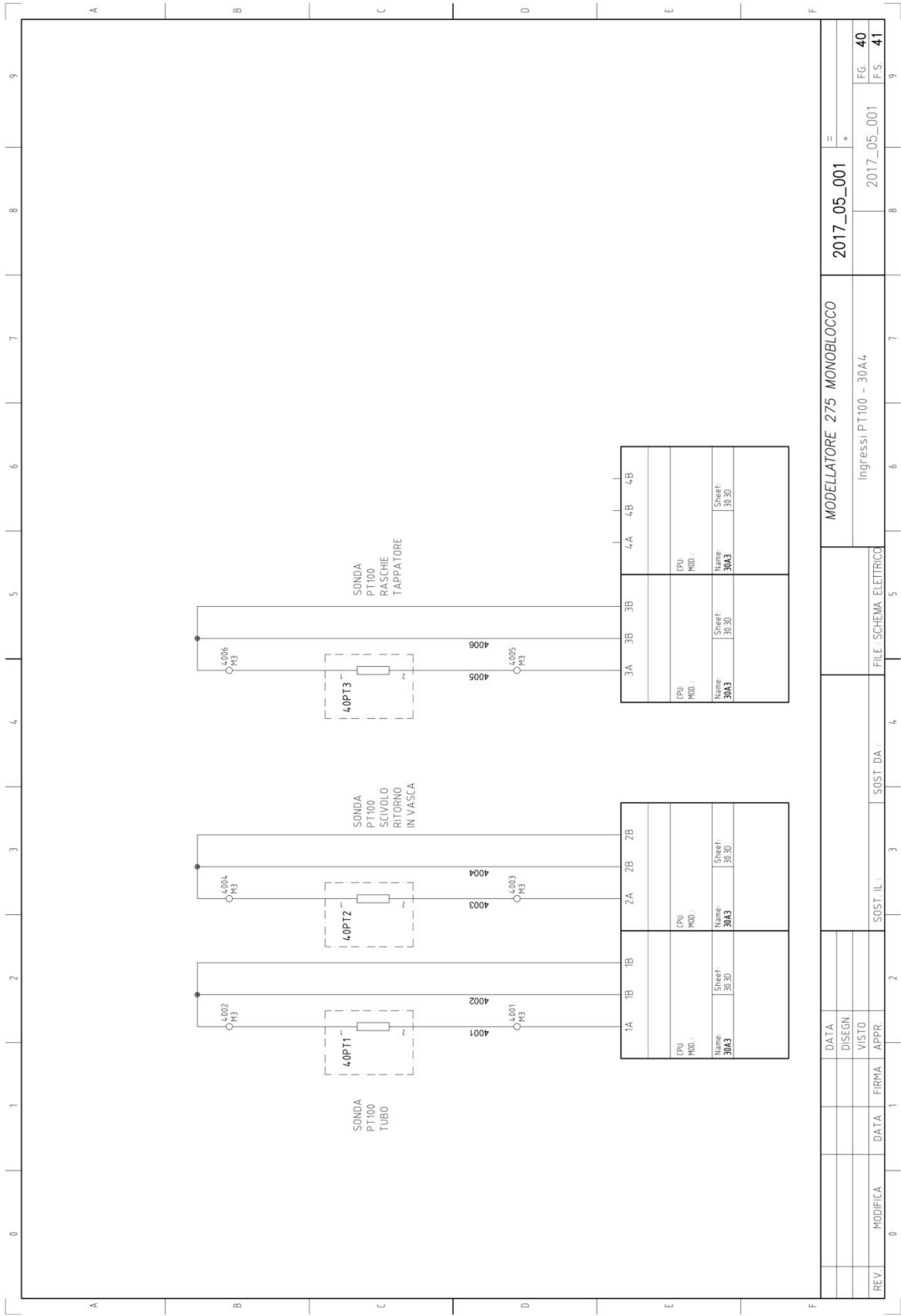

REV	MODIFICA	DATA	FIRMA	APPR.	VISTO	DISEGN.	DATA	
SOST. IL :				SOST. DA :		FILE : SCHEMA ELETTRICO		
MODELLORE 275 MONOBLOCCO							2017_05_001	
Ingressi PT100 - 30A4							2017_05_001	
							FG. 40	
							F.S. 41	

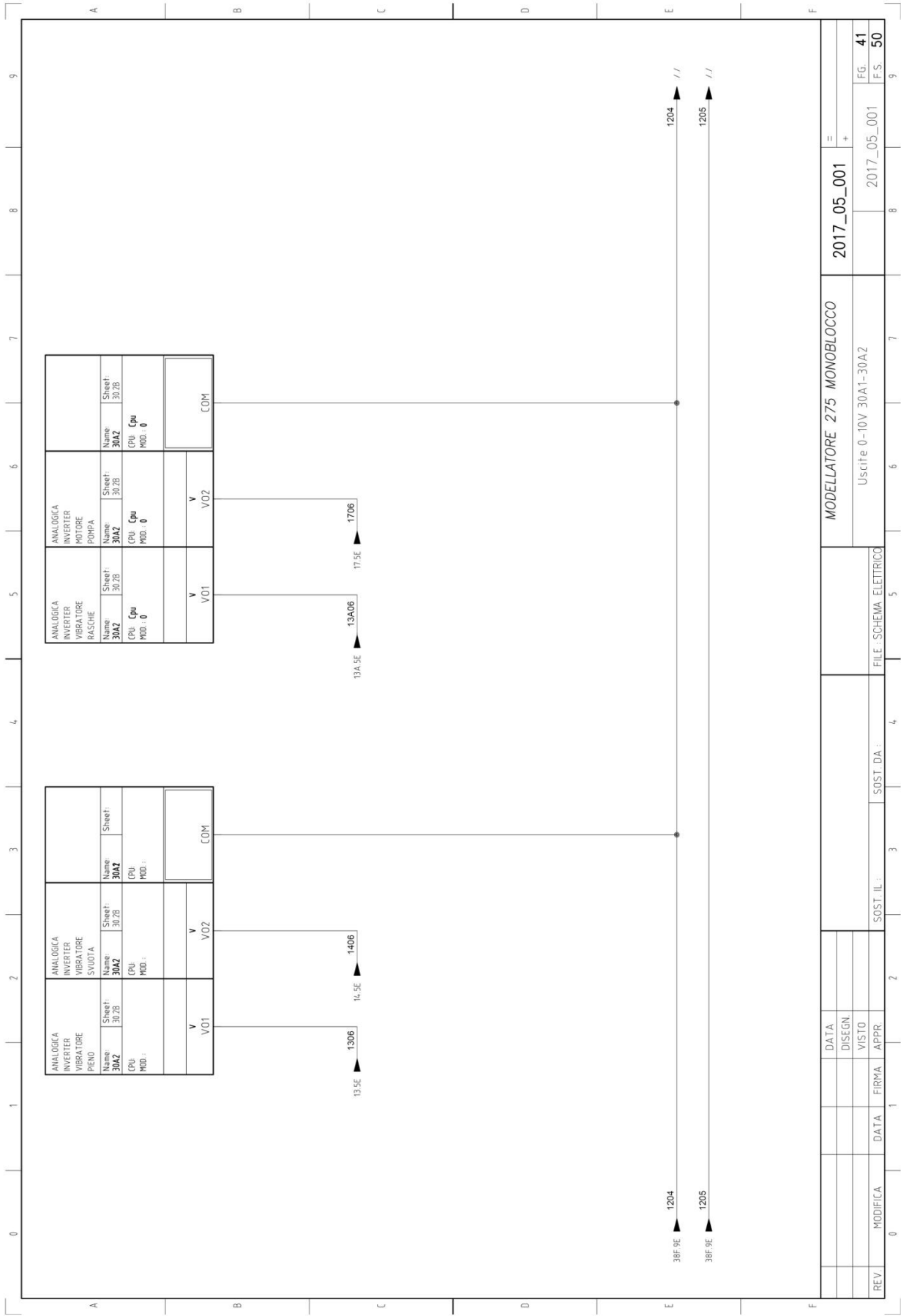

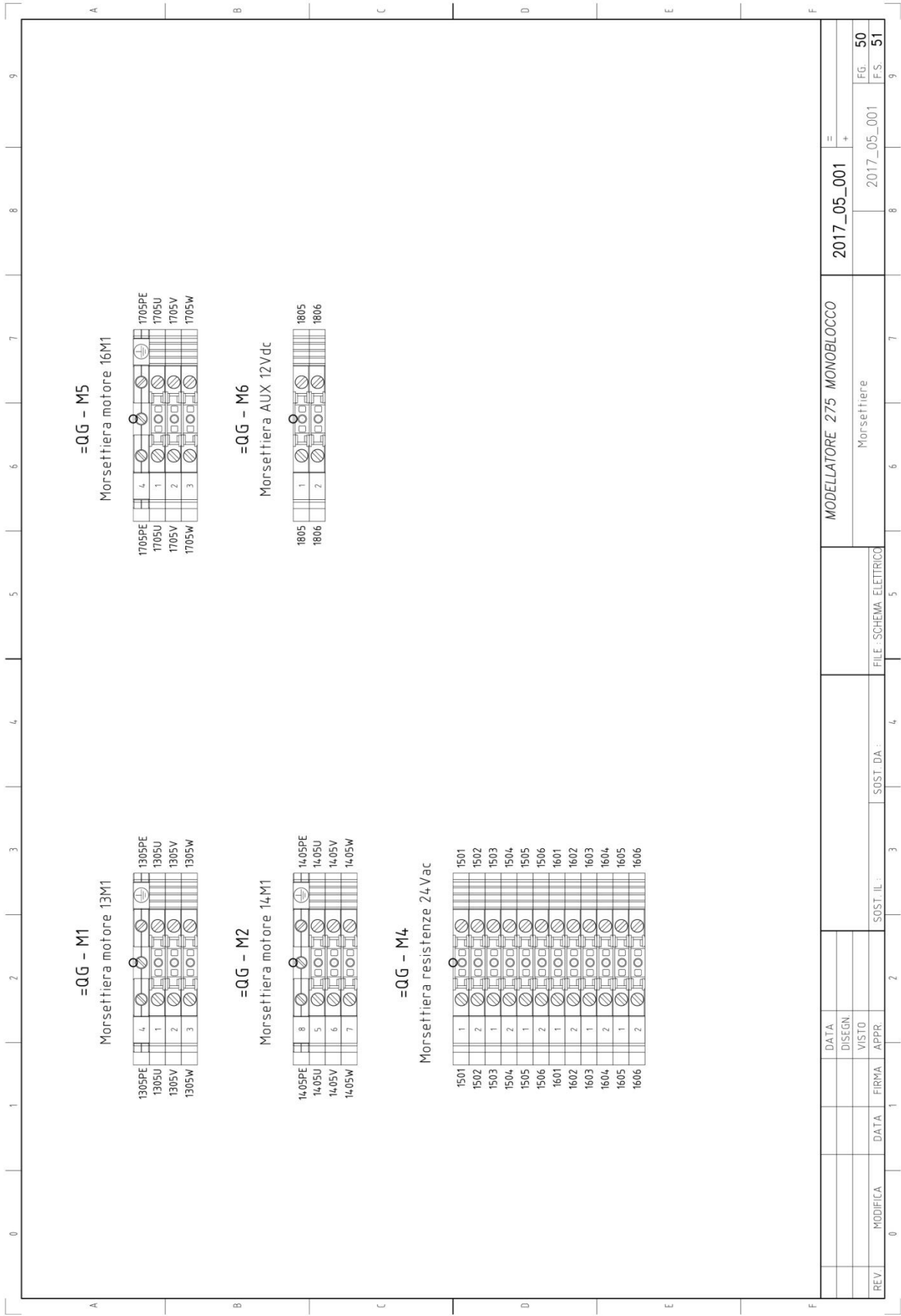

REV	MODIFICA	DATA	FIRMA	APPR.	SOST. IL :	SOST. DA :	FILE - SCHEMA ELETTRICO	MODELLO	2017_05_001	+	FG. 50
							Morsettiere	2017_05_001			F.S. 51

